Elliott-Automation Computers Limited

E-A Accessories

Technical Information

**TRM 250
Tape reader**

Copyright Elliott-Automation Limited,
1967.

In compiling this Manual every possible care has been taken to ensure its accuracy, but it must be understood that this Manual is not a Contract Document and we accept no responsibility for errors or omissions or for any damage caused to or by the equipment.

If the equipment described in this Manual is transferred by the Purchaser to another party, we recommend use by such other party of this Manual or parts. We are willing that this Manual or appropriate contents should in such event be used as part of, or in conjunction with, a Manual which may be issued by the purchaser, subject to suitable acknowledgment being made to us and subject to our approval as to the content.

Printed in England by
Engineering Unit, Elliott-Automation Computers Ltd.

PREFACE

This manual includes information relating to the four types of tape reader which comprise the medium speed range. There are two basic models, and two others which include minor additions to the circuit. The four type numbers are:

TRM 250-203 TRM 250-218

TRM 250-206 TRM 250-219

The basic models are the two whose type numbers terminate in the suffixes 203 and 206. These two models differ only in respect of the supply required for the motor. The other two readers are similar to the two basic models, but also include a circuit for the reduction of interference caused by switching surges in the motor circuit.

	Page
Chapter 4: OPERATING INSTRUCTIONS	
4.1 On/Off Switch	11
4.2 Tape Width Adjustment	11
4.3 Tape Loading	11
4.4 Tape Run-out	11
4.5 Tape Removal	12
4.6 Tape Splicing	12
4.7 Tape Repairing	12
Chapter 5: ROUTINE MAINTENANCE	
5.1 General	15
5.2 Daily Maintenance	15
5.3 Monthly Maintenance	15
5.4 Quarterly Maintenance	16
Chapter 6: PRINCIPLES OF OPERATION	
6.1 Introduction	19
6.2 Circuit Operation	21
6.3 Output Waveforms	26
6.4 Acceleration	27
6.5 Monitor Points	28
Chapter 7: SERVICING	
7.1 Tools and Materials	29
7.2 Dismantling	30
7.3 Assembly	38
7.4 Clutch Force Measurement	50
7.5 Brake Force Measurement	51
7.6 Lubrication	51

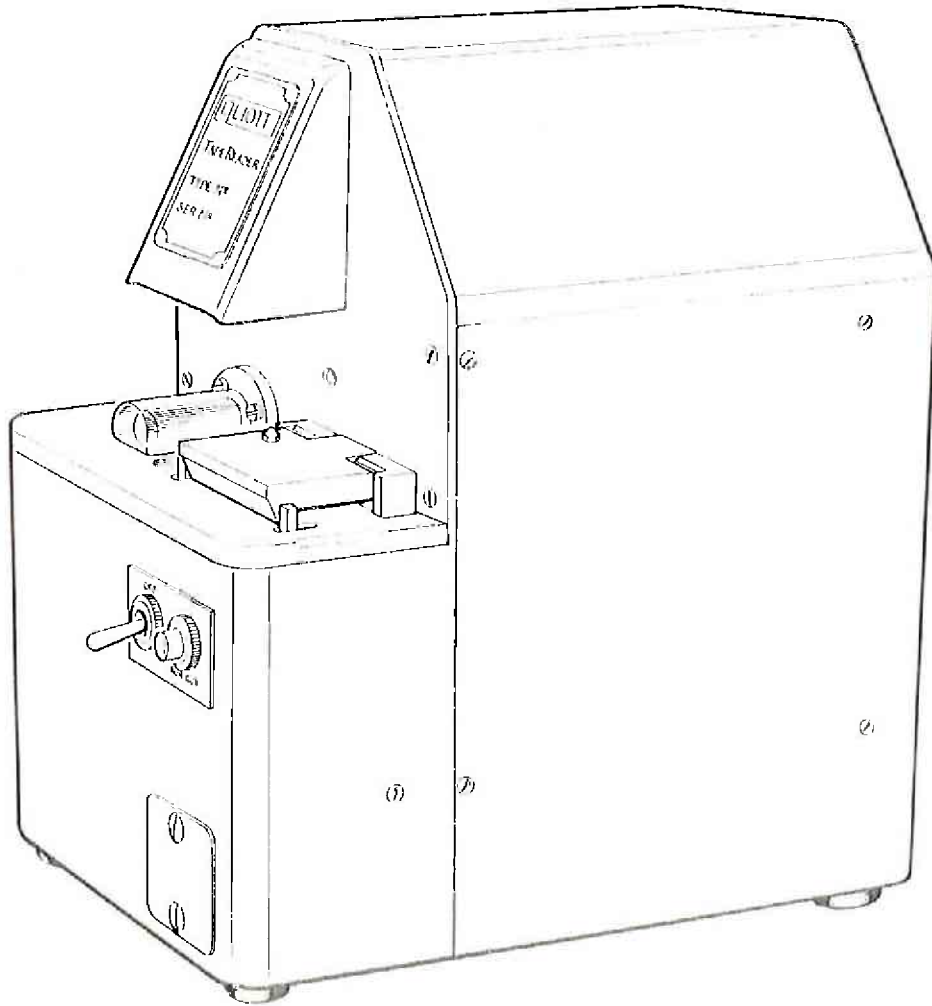

Chapter 1: INTRODUCTION

1.1 General

The Tape Readers Type TRM 250 are designed to read punched tape at speeds up to 250 characters per second, and can stop on any selected character. The tape information is sensed by silicon photovoltaic cells, and is converted into electrical signals suitable for transmission to a computer or similar equipment. Standard tape widths from $1\frac{1}{16}$ in. to 1 in. may be accommodated in the readers. The tape may be punched with data in any 5, 6, 7 or 8 channel code. Each reader is a light, compact unit capable of efficient working over a temperature range of +5°C to +45°C.

1.2 Operation

The tape is drawn through the reader by a pair of rollers, the upper roller being fixed on the end of a motor shaft. The position of the lower roller is controlled by an electromagnet, the amount of movement being sufficient to remove the drive from the tape, when desired. The tape also passes between two flat surfaces, the upper surface being hinged at the rear. The pressure between these surfaces provides a braking action on the tape.

The instrument comprises lamp, driving motor, clutch electromagnet assembly, optical system, photosensor assembly and amplifier circuits, but does not include electronic control circuits.

The supplies required are 200-250V 50 c/s, or 100-125V 60 c/s, for the motor, a 9.5V a.c. or d.c. supply for the lamp, and two stabilised supplies of 6 to 10V for the photosensors and amplifier circuits. The electromagnet coil, which has a resistance of approximately 0.5 ohms will operate correctly on 1.0A d.c.

Chapter 2: TECHNICAL SPECIFICATION

2.1 Tape Widths

Any standard width of tape, up to one inch, punched with sprocket holes and up to eight data channels, may be used.

2.2 Tape Standard

Any tape conforming to BS.3880. Waterlow Tape Type A1 is recommended. This tape is manufactured by:-

Waterlow and Sons Limited,
Paper Converting Division,
85/86 London Wall,
London, E. C. 2.

If any other tape standard is used, then the setting quoted in this manual will change.

2.3 Speed of Operation

The maximum speed of operation lies in the range 250 ± 25 characters per second. The reader will operate at any speed up to the maximum.

2.4 Output Signals

2.4.1 Polarity: Logical '0' $-0.2 \text{ volts} \pm 0.2 \text{ volts}$.

Logical '1' $V \text{ volts}$, on open circuit, where V is the negative voltage applied to PL2 pin L.

2.4.2 Waveform

Type: Square wave, substantially as shown in fig.5.

		Nominal	Permitted Range
Mark/Space ratio:	Sprocket	70:30 light/dark	68:32 to 72:28
	Data	47:53 light/dark	45:55 to 49:51

NOTE: (1) These ratios are measured at a d.c. level of $0.5V \pm 0.5$ volt, where V is the negative voltage applied to PL2 pin L.

(2) The tape used for displaying the above waveforms should be punched as shown in fig. 5, and should be run through the reader at the maximum speed.

(a) Rise time (negative-going edge) $5 \mu s$ max.

(b) Fall time (positive-going edge) $5 \mu s$ max.

2.4.3 Impedance

(a) When any sensor is illuminated, the output impedance of the associated amplifier is $560 \text{ ohms} \pm 10\%$ to the negative supply connected to PL2 pin L. An output current not greater than 20mA may be drawn from this supply to an external point connected to the 0V line, via the output connection of the amplifier.

(b) When any sensor is not illuminated, an output current not greater than 25mA may be drawn from an external load connected to a suitable external negative supply, to the 0V line via the output connection of the associated amplifier.

(c) The amplifier circuit is shown in fig. 9.

2.5 Acceleration

Time from rest to first character: 7 ms max.

Time intervals between first and subsequent characters Correspond to maximum speed of reader, in the range quoted in 2.3 above.

2.6 Power Requirements

Assembly	Voltage	Current	Max. Ripple
Motor	200-250V, 50 c/s \pm 2 c/s or 100-125V, 60 c/s \pm 2 c/s	180mA approx. 400mA approx.	- -
Lamp	9.5V a.c. or d.c.	3.5A approx.	-
* Printed Circuit Boards	+6V to +10V } nominal voltage ranges -6V to -10V }	150mA max. at +10V 300mA max. at -10V	10mV p-p 10mV p-p
Clutch	-20V d.c. if recommended circuit is used	1A	2V p-p

* NOTE: The positive and negative voltages should be equal, or within $\pm 5\%$ of the same nominal value.

2.7 Clutch Coil Impedance

0.5 ohm (resistive) and 16mH.

2.8 Connectors

Plessey Mk.4 12-way and 18-way connectors.

2.9 Overall Dimensions

Height	Width	Depth
10.5 in. (26.7 cm)	6.3in. (16.0 cm)	10.0 in. (25.4 cm)

2.10 Weight

17lb. (7.7Kg) approx.

2.11 Colour

Light grey. (Gloss)

2.12 Temperature Range

+5°C to +45°C

2.13 Humidity Range

40 to 90% R. H.

Chapter 3: INSTALLATION

3.1 Acceptance

Inspect the container for signs of damage which may have occurred during transit. If damage is evident, the carrier and insurer must be notified within seven days. Unpacking must not proceed until the insurer has given consent.

3.2 Unpacking

Unpack the reader following the instructions given in para.3.2.1. It may be advantageous to save all packing material for future reshipment of the reader.

3.2.1 Remove the outer wrapping of corrugated paper. Open the top of the cardboard box, and remove the cardboard or polystyrene packing. Check the contents of the box against the check list. Carefully remove the reader from the box. Remove the plastic dust cover from the reader.

3.3 Post-Delivery Inspection

The performance of the reader is checked prior to transit. However, a visual inspection should be carried out to ensure that no subsequent damage has occurred.

3.3.1 Remove the covers (see Chapter 7, para.7.2.1) and inspect the reader, paying particular attention to the following points:-

Ensure that all components are secure.

Ensure that the printed circuit boards are intact and are firmly pressed into their connector sockets.

Ensure that the motor spindle rotates freely, without play.

Ensure that the clutch pinch roller assembly is positioned correctly on the pivot, and that when the armature is pulled towards the core faces, the gap between the pinch roller and the capstans is reduced.

Ensure that the hinged brake assembly may be raised or lowered. Ensure that the brake pads and top plate are clean and free from grease.

Ensure that all wiring is correctly terminated.

Refit the covers.

3.4 External Connections

3.4.1 All external connections to the reader are made through two Plessey plugs situated at the rear of the reader. The connections and their functions are given below.

3.4.2 The power supplies for, and the outputs from, the signal circuits, are taken via a 12-way Plessey plug, PL2. The pin connections are as follows:-

Pin	Function	Monitor Point (see para. 6.4)
A	Data output 1	A5
B	Data output 2	A4
C	Data output 3	A3
D	Data output 4	A2
E	Data output 5	A1
F	Data output 6	B5
G	Data output 7	B4
H	Data output 8	B3
J	Data output 9	B2
K	+ve d.c. supply	B1
L	-ve d.c. supply	C5
M	0V	C4

3.4.3 The motor, clutch and lamp supplies together with the control switch circuits, are taken via an 18-way Plessey plug, PL1. The pin connections are as follows:-

Pin	Function	Monitor Point
A	Clutch	C1
B	Clutch	
C	Spare	
D	RUN-OUT switch (common)	
E	Spare	
F	Spare	
G	TAPE OUT switch (common)	
H	RUN-OUT switch (normally closed)	
J	RUN-OUT switch (normally open)	
K	Spare	
L	Spare	
M	TAPE OUT switch (tape out)	
N	TAPE OUT switch (tape in)	
O	Spare	
P	Lamp (chassis connection)	
Q	Motor supply (neutral)	
R	Lamp supply	C3
S	Motor supply (line)	

3.5 Ventilation

The flow of air from the exhaust fan must not be obstructed, as this would cause overheating of the equipment.

Chapter 4: OPERATING INSTRUCTIONS

4.1 ON/OFF Switch

The ON/OFF switch is situated at the front of the reader and controls the supplies for the motor and lamp. With the external connections made, this switch must be set to ON before the reader will operate.

4.2 Tape Width Adjustment

The tape guides locate the tape in the reader. The outer guides are adjustable for differing tape widths by moving backward or forward to the desired position. A spring detent holds each guide in position.

4.3 Tape Loading

Load the tape as follows:-

4.3.1 Raise the hinged brake assembly.

4.3.2 If necessary, set the tape guides to the correct position. These are adjusted separately.

4.3.3 Slide the tape in sideways under the capstan and lift over the tape guides.

4.3.4 Lower the hinged brake assembly.

4.4 Tape Run-Out

Clutch operation is normally controlled external to the reader. If the RUN-OUT press-button is incorporated in the external system, as recommended, depression of this button over-rides the external clutch control circuit and causes the clutch assembly to feed tape through the reader at the maximum speed.

4.5 Tape Removal

Proceed as follows:-

4.5.1 Raise the hinged brake assembly and lift the tape over the tape guides.

4.5.2 Slide the tape out sideways from under the capstan.

4.6 Tape Splicing

Proceed as follows:-

4.6.1 Overlap the two ends of the tape and align the sprocket holes.

4.6.2 Cut through the double thickness of tape with a sharp knife. If possible, make a diagonal cut.

4.6.3 Remove the loose tape end from the upper surface.

4.6.4 Without changing the position of the cut tape ends, apply a strip of adhesive tape across the butt ends. A suitable adhesive tape is opaque black Sellotape not greater than 0.003 in. thick.

4.6.5 Trim the ends of the adhesive tape with a sharp knife, so that the adhesive tape does not protrude beyond the edges of the paper tape.

4.6.6 Completely clear all holes in the paper tape obscured by the adhesive tape and ensure that light does not pass through the join.

4.7 Tape Repairing

Proceed as follows:-

4.7.1 Butt the two ends of the tape, ensuring that uniform sprocket-hole spacing is maintained.

4.7.2 Apply a strip of adhesive tape across the tear. A suitable tape is opaque black Sellotape not greater than 0.003 in thick.

4.7.3 Perform operations 4.6.5 and 4.6.6 above.

Chapter 5: ROUTINE MAINTENANCE

5.1 General

The routine maintenance on the reader consists of carrying out cleaning, inspection and lubrication at the recommended intervals. As the inspection and lubrication listed in para.5.4 necessitates the dismantling of certain parts of the reader, the details of this work are given in Chapter 7, which covers all servicing procedures. The appropriate paragraphs are referenced.

5.2 Daily Maintenance

5.2.1 The following materials are required:-

- (1) Cleaning cloth
- (2) Soft polishing cloth

5.2.2 Remove all dust and dirt from the covers of the reader.

5.2.3 Use a clean cloth to remove all dust and dirt from the tape track, including the glass window.

5.2.4 Clean the exposed surface of the prism, using the soft polishing cloth.

5.2.5 Ensure that the connecting sockets are secure in the two Plessey plugs at the rear of the reader.

5.3 Monthly Maintenance

5.3.1 The following materials are required:-

- (1) Cleaning cloth
- (2) Soft polishing cloth

(3) I. C. I. Perspex Polish No. 3.

5.3.2 Carry out the daily maintenance, excepting para. 5.2.4.

5.3.3 Remove the top cover, as detailed in para. 7.2.1.

5.3.4 Clean the lamp envelope, using the polishing cloth.

5.3.5 Clean the prism with I. C. I. Perspex Polish No. 3, using the polishing cloth.

5.4 Quarterly Maintenance

5.4.1 The following tools and materials are required:-

- (1) Cleaning cloth
- (2) Soft polishing cloth
- (3) I. C. I. Perspex Polish No. 3.
- (4) Soft brush $\frac{1}{2}$ in. wide (10014)
- (5) Feeler gauges (2020)
- (6) Screwdrivers
- (7) Hexagon Wrench 0.050 in. A. F. (2034)
- (8) Hexagon Wrench set (Fractional sizes)
- (9) Castrol S. A. E. 140 oil
- (10) B. P. CS65 oil
- (11) Shell Nerita Grease No. 3.
- (12) Dermic oiler(4306)

5.4.2 Carry out the daily and monthly maintenance.

5.4.3 Remove dust and dirt from all surfaces, using a soft brush, clean cloth, or compressed air (pressure not exceeding 60 p.s.i.) as appropriate. Take care that the air jet is not directed towards the mask or photocells.

- 5.4.4 Ensure that all components are secure.
- 5.4.5 Ensure that all wiring is secure.
- 5.4.6 Ensure that the printed circuit boards are not damaged and are correctly inserted into their connectors.
- 5.4.7 Ensure that the optical system produces uniform illumination of the apertures under the top plate window, (see para.7.3.3).
- 5.4.8 Ensure that the capstan and pinch rollers are parallel in the horizontal direction, (see para.7.3.5.1 to 7.3.5.4).
- 5.4.9 Ensure that, with the clutch released, the clearance between the capstan and pinch rollers is not less than 0.006 in. and not greater than 0.007 in., over the entire length of the capstan, (see para.7.3.5.5 and 7.3.5.6).
- 5.4.10 Ensure that, when the clutch is operated manually, and the clearance between the capstan and pinch rollers is held at 0.003 in. by the insertion of a feeler gauge, the clearance between the armature and the pole-faces is in the range 0.008 in. to 0.012 in. (see para.7.3.5.7).
- 5.4.11 Ensure that the lower brake pad is 0.002 in. to 0.004 in. above the top plate, (see para.7.3.6).
- 5.4.12 Ensure that spacing of tape guides is correct, (see para.7.3.7).
- 5.4.13 Lubricate the clutch pinch roller bracket pivot, (see para.7.6.2).
- 5.4.14 Lubricate the clutch pinch rollers, (see para.7.6.1) and recheck operation 5.4.9 after reassembly.

5.4.15 Lubricate the motor bearings, (see para.7.6.3).

5.4.16 Ensure that the clutch force is in the range 340 to 380 gm., (see para.7.4).

5.4.17 Ensure that the brake force is in the range 45-55 gm., (see para.7.5).

5.4.18 Ensure that the output waveforms exhibit the correct characteristics, (see para.6.3 and fig.5).

Chapter 6: PRINCIPLES OF OPERATION

6.1 Introduction

6.1.1 General Description

Tape reading is effected by an optical system, and tape drive and braking are by friction. An external control signal is used to actuate the friction drive which draws the tape through the reader. The drive comprises an electromagnetic clutch whose armature controls the position of a pinch roller. This roller rises and holds the tape against a rotating capstan. A continuously applied friction brake is fitted, which is capable of stopping the tape on a selected character. The read function is performed by a bank of nine photosensors, each of which feeds into an output amplifier. The amplifiers are carried on printed circuit boards. Operator controls comprise an ON/OFF toggle switch for the motor and lamp supplies, and a tape RUN-OUT press-button. All electrical connections to the reader are made by two Plessey plugs fitted at the rear. A view of the reader with the covers removed is shown in fig.2. The assemblies described in the following paragraphs are shown in this illustration.

6.1.2 Motor Drive Assembly

The motor drive assembly consists of a shaded-pole induction motor with the spindle extended at both ends. The rear end of the spindle supports an exhaust fan to cool the interior of the reader. The front end of the spindle forms a capstan for driving the tape. Four models are described in this Manual. In two models the motor is driven by a 50 c/s supply, and in the others by an 60 c/s supply. To ensure that all models give the same linear tape speed, the circumference of the capstan on the models for 50 c/s operation is increased by the addition of a sleeve.

6.1.3 Clutch Assembly

The clutch assembly consists of an electromagnet which controls the movement of a pinch roller. When the magnet is energised by an external signal, the tape is gripped between the pinch roller and the motor capstan, and drawn through the reader. With the clutch released, the distance between the pinch roller and the motor capstan is such that insufficient friction exists to draw the tape through the reader, even where tape splicing occurs.

6.1.4 Brake Assembly

The punched tape passes between two pads which produce the braking action. The lower pad is secured to the reader top plate, over which the tape passes, while the upper pad is mounted on a hinged assembly, which must be raised when tape is inserted into the reader. The upper pad is held in position by a spring mechanism, which has an adjustment to control the pressure, and hence the frictional force, on the paper.

6.1.5 Optical System

The optical system comprises lamp, focussing prism, window, light mask and photosensors. The lamp is a 12V 48W prefocus type, run at 9.5V for reliability coupled with long life. The prism is positioned such that its spherical face receives light from the lamp and converges it into a nearly parallel beam. This beam is reflected internally onto the cylindrical face, which forms a vertical beam focussed on the apertures under the glass window in the top plate. The glass window is inset in the top plate just below the tape track. It prevents dust accumulating on the light mask and photosensors. The light mask is attached to the photosensor assembly and contains shaped apertures aligned with the photosensors, which are silicon photovoltaic cells. The photosensor assembly is a replaceable plug-in unit.

6.1.6 Printed Circuit Boards

Two identical plug-in printed circuit boards carry amplifiers to convert the photosensor outputs into negative-going low impedance output signals. Each board carries a voltage stabiliser network and five identical amplifiers. The boards are located near the base of the reader. Nine of the amplifiers are used, one for each of the nine photosensors. One amplifier on the lower board is not used.

6.1.7 Tape-Out Detector

A microswitch mounted below the top plate is operated by an actuating arm when tape is inserted in the reader and the hinged brake assembly is lowered. A recess in the hinged brake assembly allows the tape-out detector arm to rise if there is no tape in the reader.

6.1.8 Tape Guides

The tape guides serve to position the tape in the reader so that the holes in the tape are aligned with the apertures of the photosensor assembly. The outer guides, which are adjustable pegs, can be set to suit the standard tape widths. The inner guides are part of the supports of the hinged brake assembly, and are fixed.

6.2 Circuit Operation

6.2.1 Switch Circuits

The ON/OFF toggle switch controls the mains supply to the motor and the low voltage a.c. or d.c. supply to the lamp. The circuit arrangement is shown in fig. 3. The resistors R35 and R36 and capacitors C2 and C3 are fitted to readers type TRM 250-218 and TRM 250-219, and serve to reduce interference caused by switching the

motor on or off.

The RUN-OUT press-button switch is wired direct to the 18-way Plessey plug and should be connected externally to the clutch control circuit. Normally, the switch connections would be arranged so that depression of the button causes continuous operation of the clutch assembly. The internal circuit arrangement is shown in fig. 3.

The TAPE-OUT switch consists of a microswitch mounted underneath the top plate with its actuating arm extending through the top plate. The switch is held in the operated state when tape is present in the reader. It is wired direct to the 18-way Plessey plug. Normally, the external switch connections would be arranged to allow clutch operation when tape is present, and to stop clutch operation and give visual or aural alarms when tape is no longer present in the reader. The internal circuit arrangement is shown in fig. 3.

6.2.2 Clutch Control Circuit

The internal circuit arrangement for the clutch coil is shown in fig. 3. The recommended clutch control circuit is shown in fig. 4. This circuit is external to the reader and requires three d.c. supplies, +10V, -10V and -20V. The +10V supply draws approximately 45mA, the -10V supply approximately 500mA and the -20V supply approximately 1A. The input to the control circuit should be taken from the collector load of a pnp transistor. This should be switched by a control waveform derived from the tape sprocket signal. The collector load of this transistor is shown as R4 on fig. 4.

When the input transistor is cut off and the control input is negative, the current flow from the -20V supply through R4, MR1 and R1 to the +10V supply gives a negative voltage on the base of VT1. This will

be sufficiently negative to cause VT1 to conduct. Due to the emitter follower action of VT1, VT2 will also conduct. When this occurs, the base voltage of VT2 falls to approximately -0.8V, and with its emitter at 0V, VT2 will pass current through the clutch coil. This will be limited to approximately 1A by R5. Tape will pass through the reader at the maximum speed as long as the input to the circuit is negative.

When the controlling transistor is switched on and the control input is at 0V, the action of MR1 will cause the base of VT1 to be at +6V. Since the emitter swing of VT1 is limited to +4V by MR2, VT1 is cut off. Consequently, VT2 is cut off, and current ceases to flow through the clutch coil. Also, as VT1 is cut off, R2 will reverse bias the base of VT2, and thus assist VT2 to switch off rapidly. When VT2 is cut off, the rapid current decay in the clutch coil generates a large back e.m.f. on the collector of VT2. This is limited to a safe value for VT2, by the zener action of MR3.

6.2.3 Information Channel Circuits

6.2.3.1 Introduction

As the tape passes over the window in the top plate, each line of holes, representing one character, allows the light to pass through to the apertures in the light mask. Nine identical photosensors are fitted in the read head assembly to detect the punched tape information, and each photosensor is connected to an amplifier mounted on one of two identical printed circuit boards. The photosensors respond to the light falling on them, and convert this energy into electrical signals. The photosensor amplifiers will switch when approximately 20% of the aperture area is illuminated by direct light through a hole. The shape of the apertures reduces the amount of diffused light which reaches the photosensors, after being transmitted through unperforated tape, and thereby reduces the photosensor outputs to a level which will not switch the amplifiers. Each character on the tape

comprises up to eight information or data holes, plus a sprocket hole. An illustration showing the relationship of the output signals to data and sprocket holes is given in fig.5. The layout of the boards is shown in figs.6 and 8 and the circuits in figs.7 and 9. Each printed circuit board carries a voltage stabilising circuit and five identical amplifiers. On the board mounted nearest the bottom cover, only four of the amplifiers are in use.

6.2.3.2 Voltage Stabilising Circuit (fig.7)

NOTE: In the text which follows and also in para.6.2.3.3. the voltage levels stated are not mandatory and should be used as a guide only.

The +ve and -ve d.c. supplies for the printed circuit boards are connected to the reader via the 12-way Plessey plug, PL2. The 0V line is also connected via PL2. From the Plessey plug the supplies are connected direct to the printed circuit board sockets SK1 and SK2. For test purposes, the supplies are also connected to monitor points B1 and C5, and the 0V line to monitor point C4. The +ve and -ve supplies may vary over the range +6V to +10V and -6V to -10V respectively, but both should be within $\pm 5\%$ of the same nominal value chosen.

Resistors R12 and R13 in parallel, zener diodes MR1 and MR2, and resistors R14 and R15 in parallel, are connected in series across the +ve and -ve supplies. The junction of MR1 and MR2 is connected to the 0V line. Zener diodes MR1 and MR2 have a zener voltage of approximately 3.3 volts. The stabilised supplies are taken from the junctions of the diodes and resistors, giving values of approximately +3.3V and -3.3V.

Resistor R16, diodes MR3 and MR4 and resistor R17 are connected in series across the stabilised supply lines. The voltage

drop across the diodes (in series) is approximately 1.1V giving a reference voltage at the junction of MR3 and R16 of approximately +0.5V and, at the junction of MR4 and R17 a reference voltage of approximately -0.6V.

Therefore, at the junction of R18 and R19, i. e. the base of VT6, a reference voltage of approximately +0.1V is obtained. The emitter of VT6 drives a load connected to the negative stabilised line. The base/emitter voltage of VT6 is approximately 0.6V giving an emitter voltage of approximately -0.5V. This is used as a bias voltage for the photovoltaic cells.

The stabilised +ve and -ve supplies are connected to the amplifiers via pins 5 and 33 respectively of SK1 and SK2, except for the stabilised +ve supply for amplifier A, which is connected direct on the printed circuit board. The emitter voltage of VT6 is used as the bias voltage for the photosensors, and is connected via pin 34 of SK1 and SK2 and the 104-way plug and socket.

6.2.3.3 Amplifiers (fig.9)

Under normal 'dark' conditions, the photosensors are not supplying an input current, and the base of VT1 has a potential of approximately -0.6V as the emitter of VT1 is at 0V. VT1 is conducting and its collector voltage is at approximately -0.3V. This voltage is applied to the base of VT2, part of the Schmitt trigger circuit, but is not sufficiently negative to cause VT2 to become fully conducting, due to the values of R4, R7 and R8. The voltage across VT2 switches on VT3, causing the emitter potential of VT2 and VT3 to fall to -1.9V. Therefore VT2 switches off. The output of the Schmitt trigger circuit is taken from VT2 collector and, with VT2 cut off, is approaching -3.3V. This potential is applied to the base of VT4, an emitter follower whose emitter load constitutes a voltage divider, R9 and R10. The output of this is applied to the base of VT5, and is held at approximately -0.6V by the emitter-base junction, since VT5 will switch on. The amplifier output is taken from VT5 collector, whose voltage under these

conditions is just below 0V. When light falls on the photosensor, the current generated by the photosensor increases the standing current in R1 and RV1. Therefore the voltage applied to VT1 base rises above 0V and VT1 is cut off. VT1 collector voltage, and thus the base voltage of VT2, fall until they reach approximately -2.5V. At this point, the base of VT2 is now negative with respect to the emitter, sufficiently enough to cause VT2 to conduct. This causes VT2 collector voltage to rise, and so VT3 switches off, as its base is fed from VT2 collector by R5 and R6, and its emitter potential is falling as the current in VT2 increases. The output from the Schmitt trigger circuit, taken from the collector of VT2, rises to approximately -1.3V and is applied to the base of the emitter follower VT4. The consequent fall in VT4 emitter current produces a rise in voltage at the junction of R9 and R10, and VT5 is cut off. With VT5 cut off, its collector voltage approaches the -ve supply, and the voltage given at the amplifier output is wholly dependent on the output current drawn from R11, the 560 ohm load.

When the light is removed from the photosensor, the collector potential of VT1 returns to approximately -0.3V. As it passes a potential of approximately -1.6V, VT2 will commence to switch off, and the circuit then returns to its original state. The method of connection of VT2 and VT3 results in the output signal changing state in either direction in approximately 5 microseconds, regardless of the rate at which the photosensor switches VT1. The potentiometer RV1 is used to adjust the input parameters to the characteristics of the associated photosensor.

6.3 Output Waveforms

The output waveform obtained from each amplifier is dependent upon the size of the hole, i.e. data or sprocket, and the setting of a potentiometer in the amplifier circuit. To adjust the waveforms, first remove the bottom cover, as described in para.7.2.1.1. This will expose the potentiometers. These are situated on the circuit boards, and may be

operated from the rear of the reader.

Insert a tape punched with the pattern shown in fig. 5. This illustration shows a 5-channel tape. The punching pattern should be extended to cover the number of channels being used. Run the tape through the reader at the maximum rate, and observe each output waveform at the corresponding monitor point. The monitor points are shown in fig. 10, and may be exposed as described in section 6.5.

Each waveform should be set to the correct mark/space ratio, as shown in fig. 5, by adjusting the corresponding potentiometer. The illustration depicts nominal settings, and shows the ideal relative timing of the data and sprocket output waveforms. The timing will be affected by any inaccuracies in the tape punching, the accuracy to which the waveforms have been set and, to a small extent, by the positioning of the read head. To provide the maximum accuracy in reading, the data signals should be strobed with a pulse which appears 240 microseconds after the leading edge of the sprocket signal.

6.4 Acceleration

When a tape is accelerated from rest, the sprocket signal relating to the first character will appear on the appropriate output line after not more than 7 ms. The signals from all further characters will appear after intervals corresponding to the maximum speed of the reader. A typical waveform is shown in fig. 11. This illustration depicts the acceleration characteristics of a reader whose maximum speed of operation lies at the mid-point of the range quoted in para. 2.3.

To achieve the above results, the clutch should be driven by the circuit shown in fig. 4.

The rest position of the tape at zero time is the position at which the tape will come to rest if commanded to stop on a character, when moving at the maximum speed of the reader. The stop signal, which switches off the clutch, should always appear at the same instant as the leading edge of the signal from a sprocket hole.

6.5 Monitor Points

On figs. 3, 7, 9 and 10 certain points on the circuit are annotated 'MP'. This indicates that these points are wired to the monitor plug. An illustration showing the pin arrangement on the monitor plug is given on fig. 10. To obtain access to the monitor plug, remove the monitor point cover assembly by releasing the two Dzus fasteners at the front of the reader.

Chapter 7: SERVICING

7.1 Tools and Materials

7.1.1 The following tools are required to complete the servicing described in this Chapter.

Feeler Gauges (2020)

Correx Tension Gauge measuring 50-500 gm. (7065)

Brake and Clutch Test Tape Clamp(1(2/4)A120212)

Salter 32oz. Compression Spring Gauge (13797)

Capstan and Clutch Alignment Gauge(1(2/4)B157021)

Capstan Height Gauge(1(2/4)B157022)

0.156 in. Slip Gauge (1(2/4)A157024) } if motor is for 50 c/s
0.312 in. Slip Gauge (1(2/4)A157027) } operation.

0.188 in. Slip Gauge (1(2/4)A157025) } if motor is for 60 c/s
Tape Width Gauge (1(2/4)A50146) } operation.

Mask Setting Gauge (1(2/4)B50145)

AMP Extractor No.465195-2 (13798)

Dermic oiler

7.1.2 The following materials are required to complete the servicing described in this Chapter.

Clear adhesive (Durofix)

Unperforated 1 in. wide paper tape (Waterlow Grade A1)

Castrol S. A. E. 140 oil

Shell Nerita Grease No. 3

B. P. CS65 oil

NOTE: In the paragraphs which follow, the numbers quoted in brackets immediately following a part description, refer to item numbers on the Illustrated Parts List, fig. 13. The parts are listed under these numbers, in numerical order, in the Parts List, Para. 8.1, Table 1.

7.2 Dismantling

WARNING: BEFORE COMMENCING TO DISMANTLE THE READER DISCONNECT THE MAINS SUPPLY BY REMOVING THE 18-WAY PLESSEY PLUG.

NOTE: Where dismantling is required to rectify a fault, or for servicing purposes, avoid dismantling sub-assemblies unnecessarily.

7.2.1 Covers

7.2.1.1 Bottom Cover Assembly

Place the reader on its side and remove four screws (148). Collect bottom cover assembly (147). Place the reader upright.

7.2.1.2 Top Cover

Remove eight screws (2) and lift off the top cover (1).

7.2.1.3 Front Cover

Unfasten two nuts (part of items 136 and 137) and collect escutcheon plate (138). Remove two screws (134) and withdraw front cover (133) complete with monitor point cover assembly (135).

7.2.1.4 Baffle Plate Assembly

NOTE: Items 44 to 46 are fitted on types
TRM 250-218 and TRM 250-219 only.

Remove screw (13) and collect washer (14).

Remove the two nuts and two washers (part of 40 and 43). Withdraw the plugs (40 and 43) to the fullest extent of the wiring, taking care to avoid damaging the electrical connections. Disconnect the wiring from the tagboard (46). Remove two screws (44) and associated nuts (44A), washers (44B) and spacers (45), to release tagboard (46). Note that there are three spacers on each screw. Remove screw (35). Remove two screws (36) and collect two washers (37). Withdraw baffle plate assembly (34) taking care to avoid damaging the blades of the fan assembly (54).

7.2.2 PV Cell Reading Head Assembly

Remove the bottom cover. Place the reader on its side and unfasten the jack screw fixed male (169) and female (N.S.). Withdraw the 104-way block (167) to the fullest extent of the wiring, taking care to avoid disconnecting the pins (168). Remove the four screws (171) and withdraw the PV cell reading head assembly (170).

7.2.3 Capstan Guard

Remove two screws (32) and collect two washers (33) and capstan guard (31).

7.2.4 Top Plate Assembly

7.2.4.1 Remove front cover, eschutcheon plate, and capstan guard.

Remove four screws (89), raise the brake cover assembly (71 to 79) and lift out the top plate assembly (56 to 88). It may be

necessary to depress the microswitch actuator (129) during this operation.

7.2.4.2 Tape Guide

Remove nut (63) and collect washer (62). Withdraw screw (61) from the upper surface of the top plate (56). Remove screw (64) and collect washer (65), adjuster backing plate (60), ball (59), adjuster spring (58) and adjuster (tape guide) (57).

7.2.4.3 Lower Brake Pad

Remove two screws (70) and collect brake pad block assembly (66 to 69). Remove two screws (69) and collect brake bottom plate (68), brake pad shim (67) and lower brake pad (66).

7.2.4.4 Upper Brake Pad

Raise the brake cover assembly (71 to 79). Restrain the upper brake pad (72) and unfasten the two grub screws (77) which lock the brake pad pins (76). Withdraw the two pins (76) complete with brake spring (75), spacer (74), damping pad (73) and upper brake pad (72).

The brake pressure setting screw (78) may be removed after loosening the locking nut (79).

7.2.4.5 Brake Cover Spring

Raise the brake cover (71). Restrain the spring support (84) and remove two screws (85). Collect two washers (86), spring support (84) and brake cover spring (83).

7.2.4.6 Brake Cover

Remove four screws (87) and collect the brake cover (71) complete with hinge blocks (81 and 82) and hinge pin (80). Remove

the hinge blocks (81 and 82) and withdraw hinge pin (80) from brake cover.

7.2.5 Optical System, Prism Plate and Brackets

7.2.5.1 Remove top cover.

7.2.5.2 Prism Cover Assembly

Support the prism cover assembly (24) and remove two screws (25). Collect two washers (26) and withdraw prism cover assembly (24) complete with name plate (27) and attaching parts.

7.2.5.3 Lamp

Remove screw (9) and connecting lead, and collect washer (10) and lamp contact (8). Remove two screws (5), and connecting lead, lift off lamp retaining plate (4) and extract lamp (15) from lamp and prism mounting bracket (3).

7.2.5.4 Prism

Carefully support the prism (18), remove two screws (19) and collect two washers (20). Ease the prism (18) away from the aperture in the prism plate (21), taking care not to scratch the prism surfaces against metal edges.

7.2.5.5 Lamp and Prism Mounting Bracket Assembly

Remove two screws (11), collect two washers (12) and lift off the lamp and prism mounting bracket (3) complete with contact post (6). Remove two screws (7) and collect contact post.

7.2.5.6 Lamp and Prism Bracket Support

Remove two screws (17) and collect lamp and prism bracket support (16).

7.2.5.7 Prism Plate

Remove four screws (22) and collect prism plate (21) complete with damping disc (23).

7.2.5.8 Prism Plate Supports

Remove four screws (143) and collect the two prism plate supports (142).

7.2.6 Fan and Motor Assemblies

7.2.6.1 Remove top cover and baffle plate. Remove screw (9) and one of the screws (5) and remove the connecting leads from the lamp mounting. Remove four screws (22) and collect prism plate (21) with the lamp and prism assembly attached.

7.2.6.2 Fan Assembly

Remove grub screw (55) and withdraw fan assembly (54) from spindle of motor (47).

7.2.6.3 Motor Assembly

Disconnect the two terminal pins (49) from the flexible terminal block (144). Support the motor assembly (47 to 50) and remove four screws (52). Collect four washers (53). Withdraw the motor assembly (47 to 50) and collect four motor shims (51). Note the position of each shim to ensure that on assembly they are replaced in their correct positions.

7.2.7 Clutch Assembly

7.2.7.1 Remove front cover, escutcheon plate, bottom cover, capstan guard and top plate. Place the reader on its side, support the clutch assembly (90 to 120) and remove the four screws (122). Collect four washers (123) and withdraw the clutch assembly sufficiently far to give access to the tagboard assembly (118). Unsolder the wiring of the reader from the tagboard. Remove the clutch assembly and collect the clutch bracket shims (121).

7.2.7.2 Pinch Rollers

Remove two screws (111) and collect locking plate (110). Slide out clutch roller shaft (107) collecting pinch rollers (108) and roller spacers (109) as the shaft is withdrawn. Note the order of collection of the rollers and spacers and the individual arrangement of each, so that on re-assembly they can be replaced with the correct arrangement, i. e. in the correct order and with none reversed.

7.2.7.3 Clutch Armature

Unfasten the two locknuts (104) to relieve the tension on the clutch spring (105). Remove the clutch spring (105) and slide out the adjusting stud (103) complete with locknuts (104). Remove the two screws (114) and collect two washers (115). Withdraw the clutch roller bracket (106) and collect clutch armature shims (113). Note the number and thickness of shims. Withdraw the clutch armature (112), loosen the locking nuts (117), and remove the grub screws (116).

7.2.7.4 Coils

Unsolder the coil connections from the tags on the tagboard assembly (118). Remove the two bolts (100) and collect the two nuts

(101), washers (102) and lower lamination clamp (99). Remove the lamination assembly (98) complete with coils (97) from the clutch bracket (90). Slide the coils (97) off the lamination assembly.

7.2.7.5 Stop Block

Remove the two screws (94) and collect the stop block (93). The adjusting grub screw (95) may be removed after loosening the locking screw (96).

7.2.7.6 Clutch Roller Bracket Pivot

Remove the two screws (92) and collect the clutch roller bracket pivot (91).

7.2.7.7 Tagboard Assembly

Remove the two screws (120) and collect the tagboard assembly (118) and insulator (119).

7.2.8 Switches and Terminal Block

7.2.8.1 Remove front cover, escutcheon plate, bottom cover, top cover, capstan guard and top plate.

7.2.8.2 'TAPE OUT' Switch

Disconnect the wiring from the microswitch (128). Remove the two nuts (131) and collect two washers (132). Slide the microswitch (128) complete with actuator (129) off the screws and remove the two screws (130) from the microswitch bracket (124).

7.2.8.3 Microswitch Bracket

Remove the two nuts (126) and collect two washers (127), microswitch bracket (124) and two screws (125) from the base assembly (162 to 166).

7.2.8.4 ON/OFF Switch and RUN-OUT Press-Button

Disconnect the wiring from the toggle switch (136) and microswitch (137). Remove the locking nuts and withdraw the switches from the switch bracket (139).

7.2.8.5 Switch Bracket

Place the reader on its side. Remove two screws (140), and collect two washers (141) and switch bracket (139).

7.2.8.6 Flexible Terminal Block

Disconnect the wiring from the block. Remove two screws (145) and collect two washers (146) and flexible terminal block (144).

7.2.9 Printed Circuit Boards and Sockets

7.2.9.1 Remove the bottom cover.

7.2.9.2 Printed Circuit Board Assemblies

Place the reader on its side and withdraw the two printed circuit board assemblies (149) from their sockets (150), and through the guides in the two rear base supports (157 and one not shown).

7.2.9.3 Printed Circuit Socket Assemblies

Remove the four screws (151) and withdraw the socket assemblies (150) to the fullest extent of the wiring, taking care that

the electrical connections are not damaged. Disconnect the wiring by removing the terminals from the housing using an AMP extractor type 465195-2. (Cat.No. 13798).

7.2.9.4 Printed Circuit Socket Support Brackets

Remove the four screws (153) and collect the two circuit board support brackets (152).

7.2.10 Base Supports

Remove bottom cover, top cover and printed circuit boards. Remove the four screws (166) and polythene feet (165) - these items are part of the base assembly (162 - 166). Remove the four screws (160) and collect four washers (161), two base support left-hand assemblies (157, one not shown) and one base support right-hand assembly (not shown). Withdraw the monitor point plug sub-assembly (158) to the fullest extent of the wiring, taking care not to damage the electrical connections to the plug or resistors (159). Unsolder the wiring.

7.3 Assembly

NOTE: Assembly is, in general, the reverse procedure to dismantling. Special procedures to be followed for alignment and adjustment, during or following assembly, are covered by the following sections.

7.3.1 Wiring Connections

In connecting the wiring, ensure that the correct connections are made (refer to fig.10), and that there are no dry joints and that the sleeving and components are not overheated.

7.3.2 Printed Circuit Boards

On inserting the printed circuit boards, ensure that neither the sockets nor the components are damaged.

7.3.3 Optical System

7.3.3.1 Uniformity of Illumination

Check that the illumination provided by the lamp is evenly distributed over the apertures below the window in the top plate. A uniform distribution may be obtained by adjusting the lamp and/or the prism.

7.3.3.2 Prism Adjustment

Elongated holes in the lamp and prism mounting bracket (3) permit longitudinal movement of the lamp and prism relative to the window, whilst maintaining the position of the lamp relative to the prism. The prism may also be adjusted relative to the mounting bracket to facilitate lateral positioning of the illuminated zone.

Remove the top cover (1). Loosen the lamp and prism mounting bracket securing screws (11 and 13). Position the bracket so that the apertures under the window are evenly illuminated. Tighten the securing screws. If lateral movement of the illuminated zone is required, slacken the two screws (19) securing the prism to the lamp and prism mounting bracket, and rotate the prism to position the illuminated zone correctly. Tighten the securing screws.

7.3.3.3 Lamp Adjustment

The uniformity of illumination of the apertures also depends on the position of the lamp filament. Check the lamp filament for sagging and renew the lamp if necessary.

Remove the top cover (1). Loosen the screws(5) securing the lamp retaining plate (4) to the lamp and prism mounting bracket. Rotate the lamp (15) to obtain maximum intensity of illumination on the window. Tighten the lamp plate securing screws (5) and refit the top cover (1).

NOTE: The normal position of the lamp is such that the lamp filament support and the prism are on opposite sides of the filament, so that the filament support does not cast a shadow on the prism.

7.3.3.4 Replacement of the Light Mask

Detach the reading head as detailed in para.7.2.2. Place the Mask Setting Gauge (1(2/4)B50145) over the reading head, either way round, and position it so that one end of the slot is against the datum end of the head, i.e. the end with the engraved line. Place mask in slot in gauge, after coating the underface with a minimum quantity of Durofix, so that the end with the red dot is against the end of the slot placed against the datum end of the head. The sides of the slot will align the mask correctly. Before fitting a new mask, clean off the underface using fine wet and dry paper, used dry. Clean the surface until bright. Clean off the top face of the collimator block in a similar way.

7.3.3.5 Replacement of Photosensors

CAUTION 1: THE PHOTSENSORS ARE SUPPLIED COMPLETE WITH LEADS. DO NOT APPLY A SOLDERING IRON DIRECT TO THE CONNECTIONS ON THE BASE OF THE SENSOR.

CAUTION 2: THE READING HEAD MUST NOT BE DISMANTLED BEYOND THE REMOVAL OF THE COLLIMATOR BLOCK, PHOTSENSOR RETAINER AND PHOTSENSORS. THE POSITIONS OF OTHER PARTS MUST NOT BE DISTURBED.

Detach the reading head as detailed in para. 7.2.2.

Unsolder the signal lead of the faulty photosensor from the tagstrip, and remove the sleeve. Cut the other lead, supplying the bias voltage, just below the connection on the base of the sensor. Withdraw the lead downwards through the sleeve containing the bias leads to the other sensors, and cut it from the tag on the tagstrip. Take care that no other connections are disturbed.

Remove the two screws which secure the tufnol photosensor retainer. It may be necessary to remove the collimator block in order to reach the screws holding the retainer. To release the collimator block, remove the two countersunk screws in the top surface. Note which way round the collimator block is fitted. It must not be reversed on re-assembly. DO NOT DISTURB ANY OTHER SCREWS OR PARTS OF THE READING HEAD.

NOTE: When the collimator block securing screws are removed, IT IS ABSOLUTELY ESSENTIAL THAT THE SUPPORTING PILLARS ARE HELD SECURELY to prevent any rotation and consequent loss of adjustment. If the position of either pillar is disturbed, it will be impossible to replace the collimator block in the correct position without resetting the complete assembly.

When the collimator block securing screws have been removed, ease the block sideways away from the support pillars, taking care not to place any strain on the connecting leads to the sensors. The two screws securing the photosensor retainer may then be removed, and the retainer eased sideways from under the collimator block. The sensors will remain attached to the retainer. Remove the faulty sensor, and insert a new sensor by feeding the leads through the two holes in the retainer. Take care to insert the sensor the correct way round, so that the positive pin on the base is in line with the positive pins on the other sensors. Replace the retainer under the collimator block, and replace the two securing screws. Feed the leads through their respective sleeves, one of which was removed from the faulty sensor, and solder to the appropriate points on the tagstrip.

7.3.3.6 Photosensor Outputs

After replacement of a photosensor, the output of the new sensor should be checked. If either the lamp or prism has been readjusted, or the lamp, prism or mask has been replaced, the output of each photosensor should be checked.

To check the output of a photosensor, first remove the bottom cover and then withdraw the 104-way block (167) as described in para.7.2.2. Connect the lamp supply, and ensure that the lamp voltage, measured at the lamp, is $9.5V \pm 0.1V$. Connect a 2,000 ohm load between the appropriate pins on SK3. This socket forms the base of the reading head. The pin connections for each cell are shown in fig.10.

The current supplied to the 2,000 ohm load by the cell must be not less than 120 microamps.

NOTE: The resistance of an Avometer Model 8, when switched to the 250 microamp range, is 2,000 ohm. A Model 8 may therefore

be used as the load, when switched to this range. Whatever meter is used, the internal resistance must be included as part of the load.

7.3.4 Motor Replacement and Alignment

7.3.4.1 Motor Replacement

Remove the old motor as detailed in para.7.2.6 and remove the top plate assembly as detailed in para.7.2.4. Place the replacement motor in approximately the correct position and secure by means of the four fixing screws (52) and washers (53).

7.3.4.2 Motor Height Adjustment

Place the Capstan Height Gauge (1(2/4)B157022) on the ground faces of the base plate (162) in place of the top plate assembly. Measure the distance between the gauge and the top of the motor capstan as follows:-

If the motor to be fitted is for 50 c/s mains operation, position the height gauge so that the larger recessed section is over the capstan. Hold a 0.312 in. slip gauge (1(2/4)A157027) over the capstan and against the underface of the height gauge, and use feeler gauges to measure the gap between the slip gauge and the capstan. The gap should be 0.002 in. to 0.003 in.

If the motor to be fitted is for 60 c/s mains operation, position the height gauge so that the smaller recessed section is over the capstan. Use feeler gauges to measure the gap between the recessed section and the capstan. The gap should be 0.005 in. to 0.006 in.

In neither case should the gap vary by more than 0.0005 in. over the length of the capstan.

If the gaps measured do not comply with the dimensions given, add shims (51) as required under the motor base plate (48).

NOTE: When adding shims, always shim both front, or both rear points by the same amount, to prevent strain on any of the parts involved.

7.3.4.3 If the clutch assembly is in position in the reader, slacken the four securing screws (122) slightly, and move the clutch assembly as far as possible towards the photocell assembly. Then place the Capstan and Clutch Alignment Gauge (1(2/4)B157021) on the ground faces of the base plate, in place of the top plate assembly. Locate the gauge by means of the two dowels projecting from the ground faces of the base plate and the two slip bushes, which should be locked in position in the gauge. Measure the distance between the capstan and the gauge, as follows:-

If the motor to be adjusted is for 50 c/s mains operation, fasten a 0.156 in. slip gauge (1(2/4)A157024) to the upper vertical face of the alignment gauge, and use feeler gauges to measure the gap between the slip gauge and the capstan.

If the motor to be adjusted is for 60 c/s mains operation, proceed as stated above, using a 0.188 in. slip gauge (1(2/4)A157025).

In either case, the gap may be 0.008 in. to 0.012 in. but should not vary by more than 0.0005 in. over the length of the capstan.

7.3.4.4 To achieve these conditions, slacken the four motor base securing screws (52) slightly, and adjust the motor position to give the correct gap alongside the capstan. Sufficient clearance exists about the securing screws (52) to allow this to be done. Tighten the screws when the motor is correctly set, and recheck setting.

7.3.4.5 After positioning the motor correctly, the alignment of the capstan and the clutch pinch rollers must be reset, as stated in section 7.3.5. The adjustment must be achieved by positioning the clutch assembly correctly. Do not make further adjustments to the position of the motor, unless the clearances round the clutch assembly securing screws (122) do not permit the required movement of the clutch. If this condition is reached, the motor should be moved in the appropriate direction, and reset according to the details given in para.7.3.4.3.

7.3.5 Clutch Pinch Roller Alignment

NOTE: When adjustments are made to the position of the clutch assembly, as given in para.7.3.5.2 and 7.3.5.3 below, care must be exercised so that the clutch roller bracket (106) is not lifted off the pivot (91) by bringing the rollers and the Alignment Gauge (1(2/4)B157021) into contact under excessive pressure. To counteract the tendency of the bracket to lift, the two grub-screws (116) may be screwed down gently onto the polefaces of the solenoid, and locked in position by the nuts (117). Return the screws to their original positions before adjusting the Capstan/Pinch Roller gap and the Clutch Armature gap (paras.7.3.5.5 to 7.3.5.7).

7.3.5.1 The clutch pinch rollers must be correctly positioned relative to the motor capstan. The alignment of these two parts should be checked after a new motor or clutch assembly has been fitted, or after any work which has involved disturbing the motor or the pinch rollers.

7.3.5.2 If a new motor has been positioned as stated in para.7.3.4.3, it is necessary to reposition the clutch assembly. Lock the Capstan and Clutch Alignment Gauge (1(2/4)B157021) in position as described in para.7.3.4.3, and move the clutch assembly until the pinch rollers are in contact with the lower vertical face of the gauge, over the entire length of the rollers. Secure the clutch assembly in this position, and check the setting as described in para.7.3.5.3.

7.3.5.3 To check the clutch setting, release the gauge by slackening the slip bush locking screws 2 to 3 turns, and removing the slip bushes. The gauge is then free to slide on the ground faces of the base plate.

Adjust the position of the gauge so that the lower vertical face of the gauge is in contact with the pinch rollers over their entire length. Hold the gauge in this position, and measure the gap between the motor capstan and the gauge, using the appropriate slip gauge, as stated in para.7.3.4.3. If the gap is as stated, the clutch setting is correct. If the gap is not as stated, reposition the clutch assembly as required, to achieve the correct conditions.

NOTE: If it is not possible to move the clutch assembly to the desired position, follow the procedure of para.7.3.4.5.

7.3.5.4 If the clutch assembly is being renewed, or repositioned after servicing, and the motor position has not been altered, lock the alignment gauge in position as stated in para.7.3.4.3. Ensure that the motor is in the correct position by following the procedure given in para.7.3.4.3, and then adjust the position of the clutch assembly as stated in paras.7.3.5.2 and 7.3.5.3.

7.3.5.5 Capstan/Pinch Roller Gap

Remove the Capstan and Clutch Alignment Gauge. Use feeler gauges to measure the gap between the capstan and the clutch pinch rollers, with the clutch in the de-energised state. The gap should be 0.006 in. to 0.007 in. and should not vary by more than 0.0005 in. over the length of the rollers. If the gap variation is greater than this, lower the appropriate end of the clutch roller bracket pivot (91), to reduce the variation to a permissible figure. A light tap, on the unused portion of the knife edge, will produce the required effect. When the gap variation is within the required limits, the gap may be adjusted as in the next paragraph.

7.3.5.6 To adjust the gap, slacken the locking screw (96) and turn the stop screw (95) to give the correct conditions. When the gap is 0.006 in. to 0.007 in., retighten the locking screw. If the amount of correction required cannot be achieved by adjusting the stop screw (95), insert shims (121) as required, between the clutch assembly and the reader base. To insert shims (121) it is necessary to remove four screws (122). Therefore, the conditions of para.7.3.5.3 will be lost, and the clutch assembly must be reset as stated in paras.7.3.5.2 and 7.3.5.3.

NOTE: Item 121 is laminated, each layer being
0.002 in. thick.

7.3.5.7 Clutch Armature Gap

With the clutch operated, and the clearance between the capstan and the pinch rollers held at 0.003 in., the clearance between the armature and the polefaces of the clutch must lie between 0.008 in. and 0.012 in.

Insert a 0.003 in. feeler gauge between the capstan and pinch rollers and operate the clutch by hand. Use feeler gauges to measure the gap between the armature and the polefaces. If the clearance is not within the limits, release the clutch armature (112) from the clutch roller bracket assembly (106) by removing the screws (114) and washers (115). Increase or decrease the number of clutch armature shims (113) as necessary, to give the required clearance. Re-assemble the clutch armature, and recheck the clearance. Reset the two grub screws (116) as stated in para. 7.3.5.8.

NOTE: The armature shims (113) are available in two thicknesses, 0.001 in. and 0.005 in.

7.3.5.8 Pinch Roller Travel Limiting Screws

Slacken the two locking nuts (117). Hold the armature down so that the grub screws (116) are in contact with the polefaces, and adjust the grub screws so that a small gap is present between the pinch rollers and the capstan. This gap must be not greater than 0.002 in. Ensure that both grub screws touch their respective polefaces at the same time. Tighten the nuts and recheck the setting.

NOTE: For adjustment of pinch roller end float, see para. 7.6.1.

7.3.5.9 Clutch Spring Tension

Apply a compression spring gauge to one of the two clutch armature retaining screws (114) situated at the yoke end of the clutch roller bracket assembly (106). Check that the clutch armature moves towards the polefaces, when a pressure of 22oz. \pm 2oz. is applied. If the pressure measured lies outside the limits stated, loosen the locking nuts (104) and increase or decrease the tension in the spring (105) accordingly. Tighten the locking nuts (104) and recheck the pressure.

NOTE: It is necessary to remove the reading head assembly (170) to gain access to the locking nuts (104).

7.3.6 Lower Brake Pad

The lower brake pad should project above the surface of the top plate by 0.002 in. to 0.004 in. To check the setting, raise the hinged brake assembly and hold a straight edge across the exposed face of the lower brake pad. Use feeler gauges to measure the gap between the straight edge and the surface of the top plate. If the gap lies outside the limits stated, adjust as follows:

Remove the front cover, escutcheon plate, capstan guard and top plate. Remove two screws (70) and collect the lower brake pad assembly. Remove two screws (69) and collect the lower brake pad (66), the laminated shim (67) and the bottom plate (68). Remove or add laminations to correct the height of the lower brake pad. Each lamination is 0.002 in. thick. Reassemble the lower brake pad assembly and screw in position in the top plate. Recheck the height of the lower brake pad above the top plate.

7.3.7 Tape Guides

Raise the hinged brake assembly, and set both of the tape guides (57) to the widest setting. Place the Tape Width Gauge (1(2/4) A50146) in the reader so that it rests on the top plate with the straight edge against the fixed rear tape guides. Check that each adjustable guide is correctly positioned by testing the width between it and the rear guide with the "GO" and "NO GO" sections of the gauge. If either adjustable guide is not in the correct position, proceed as follows. Remove the front cover, escutcheon plate, capstan guard and top plate. Slacken the two screws (61 and 64) securing the adjuster backing plate (60) just sufficiently to enable the plate to slide. Move the plate as necessary to position the adjuster correctly. Retighten the screws and recheck the setting.

7.4 Clutch Force Measurement

NOTE: During this measurement, the hinged brake assembly should be lifted.

7.4.1 With the clutch energised and the motor running, the force required to keep an unperforated length of 1 in. wide paper tape just moving backwards through the reader must not be less than 340 gm. and not greater than 380 gm.

7.4.2 Insert a length of unperforated 1 in. wide paper tape into the reader. Secure the right hand end (viewed from the front of the reader) to a Correx Spring Tension Gauge (50-500 gm.) with the Brake and Clutch Test Tape Clamp (1(2/4)A120212). Start the motor and operate the clutch. Draw the tape slowly backwards through the reader, keeping the gauge arm at right angles to the tape, and the tape horizontal. Check that the force required to keep the tape just moving lies within the limits stated. If the reading is not within the limits, one of the checks in paras. 7.3.5.7 and 7.3.5.9 must be carried out.

The removal or addition of one clutch armature shim (113) will alter the clutch force by approximately 50 gm.

CAUTION: WHEN THE READER IS OPERATING, CARE MUST BE TAKEN TO AVOID DRAWING THE CLAMP INTO THE READER.

7.5 Brake Force Measurement

7.5.1 With the clutch released, the force required to keep an unperforated 1 in. wide length of paper tape just moving forwards through the reader must be not less than 45 gm. and not more than 55 gm.

7.5.2 Insert a length of 1 in. wide paper tape into the reader, and secure the left-hand end (viewed from the front of the reader) to the Correx Spring Tension Gauge (50-500 gm.) with the Brake and Clutch Test Tape Clamp (1(2/4)A120212). Draw the tape slowly forwards through the reader, keeping the gauge arm at right angles to the tape, and the tape horizontal. Check that the force required to keep the tape just moving lies within the limits stated.

7.5.3 If the gauge reading lies outside the limits, release the nut (79) and adjust the spring pressure adjusting screw (78) on the hinged brake assembly to produce the required reading. Tighten the nut (79) and recheck the gauge reading.

7.6 Lubrication

7.6.1 Pinch Rollers

7.6.1.1 Remove the front cover, escutcheon plate, capstan guard and top plate. Remove the two screws (111) and locking plate (110). Slide out the clutch roller shaft (107) from the clutch roller bracket (106) and collect the pinch rollers (108) and roller spacers (109),

noting the order of removal and the individual arrangement of each, so that on re-assembly they can be replaced with the correct arrangement, i. e. in the correct order and with none reversed.

7.6.1.2 Clean off all oil and dirt from the parts, and temporarily reassemble in the correct order without lubricant. Check that the gap between any two rollers is between 0.006 in. and 0.009 in. Check that the rollers spin freely.

7.6.1.3 Remove the rollers and spacers and lubricate inside each roller with three drops of B. P. CS65 oil from the dermic oiler.

7.6.1.4 Reassemble the rollers and spacers in the correct order on the shaft, and secure in place, (see para.7.6.1.1).

NOTE: If a replacement pinch roller (108) or clutch roller shaft (107) is required, a new shaft, complete with three new rollers, must be fitted. These are supplied as a set, Part No. A7462. For the correct use of this set, see Appendix 1.

7.6.2 Pinch Roller Bracket Pivot

Remove the front cover and escutcheon plate. Place the reader on its back. Place one drop of S. A. E. 140 oil on the exposed end of the knife edge pivot, using the dermic oiler. Allow the oil to run down the knife edge, before restoring the reader to its base.

7.6.3 Motor Bearings

7.6.3.1 Remove the top cover and capstan guard. Remove the grub screws at the top of each end of the motor casing to reveal

the greasing points.

7.6.3.2 Inject a small amount of Shell Nerita Grease No. 3 into each greasing point using the dermic oiler. Wipe off any excess grease.

7.6.3.3 Replace the grub screws, top cover and capstan guard.

7.7 Operational Test

7.7.1 Prepare a 1 in. wide length of paper tape containing approximately 300 characters, and splice the two ends together as in para. 4.6. Place the loop in the reader. Run the loop at the maximum speed, with the clutch held on continuously. Check that the tape speed is correct by observing the sprocket waveform on an oscilloscope. The sprocket hole signals should appear every 4 msec.

7.7.2 If the tape speed is not correct, check the clutch adjustments as detailed in Section 7.4 and brake adjustment as detailed in Section 7.5. A small adjustment of one of these forces, within the limits quoted, will enable the correct maximum speed to be achieved.

7.8 Fault Finding

Symptom	Probable Cause	Remedy
1. Tape slipping, or not stopping in correct position	Clutch out of adjustment	Check and adjust
	Brake pads dirty, or out of adjustment	Clean, check and adjust
2. No output signals	Dirty window or mask	Clean
	Optical mis-alignment	Re-align
	Light mask out of position	Refasten

Symptom	Probable Cause	Remedy
3. No output on one channel	Photosensor or printed circuit board faulty	Change over printed circuit boards and locate faulty component
	Non-uniform illumination of mask apertures	Re-align prism and lamp
4. Tape damaged in reader	Seized rollers	Clean and lubricate
	Burred brake pad	Renew

Chapter 8: TABLES

8.1 Table 1 - Parts List

Introduction

The method of presentation used in this list is as follows:

- | | | |
|-----|---------------------|---------------------------------------|
| (1) | Assembled sub-unit. | Part description not indented. |
| (2) | Component of (1) | Part description indented one space. |
| (3) | Component of (2) | Part description indented two spaces. |

The Item Numbers are shown on the Illustrated Parts List

fig. 13.

- NOTES: 1. The quantities of screws, nuts and washers listed in the spares column represent the recommended total numbers of each type, and are entered against the first appearance of each type in the table.
2. When ordering spare parts, always quote the Part Number, never the Item Number, and give the type and serial numbers of the reader(s) for which the parts are required.

TABLE 1

Item No.	Part No.	Description	No. off	Recommended Spares
1	D4/22/C593	Top Cover	1	
2	D4/5/195J	Screw 6 BA x $1/4$.Mush.Hd.	8	4
-	D4/22/B280	Lamp and Prism Mounting Bkt. Assy.	1	
3	D4/22/B278	Lamp and Prism Mounting Bkt.	1	
4	D4/22/A412	Lamp Retaining Plate	1	
5	S425E	Screw 4 BA x $5/16$.Ch.Hd.	2	1
6	D4/22/A49	Contact Post	1	
7	S653A	Screw 6 BA x $3/8$.Csk.Hd.	2	1
8	D4/22/A50	Lamp Contact	1	
9	S496E	Screw 4 BA x $3/8$.Ch.Hd.	1	3
10	W384E	Washer 4 BA Small	1	1
11	S488E	Screw 4 BA x $1/4$.Ch.Hd.	2	2
12	W400E	Washer 4 BA Small	2	1
13	D4/5/252	Screw 4 BA x $1/4$.Pan.Hd.	1	1
14	W68E	Washer 4 BA Large	1	1
15	D4/6/826	Lamp 12V.48W.(Lucas 185)	1	3
16	D4/22/A2346	Lamp and Prism Bracket Support	1	
17	S437E	Screw 4 BA x $7/16$.Csk.Hd.	2	
18	D4/22/A61	Prism	1	
19	S6019E	Screw 6 BA x $1/2$.Ch.Hd.	2	2
20	W412E	Washer 6 BA Small	2	4
21	D4/22/C525	Prism Plate	1	
22	D4/5/129J	Screw 6 BA x $3/8$.Mush.Hd.	4	2
23	D4/22/A504	Damping Disc	1	
24	D4/22/B548	Prism Cover Assembly	1	
25	S628E	Screw 6 BA x $3/8$.Ch.Hd.	2	2

Item No.	Part No.	Description	No. off	Recommended Spares
26	W412E	Washer 6 BA Small	2	
27	D4/22/A54	Name Plate	1	
28	D4/5/134J	Screw 10 BA x $\frac{3}{16}$.Inst.Hd.	4	
29	D4/5/150E	Washer 10 BA	4	
30	D4/5/117E	Nut 10 BA	4	
31	D4/22/B711	Capstan Guard	1	
32	S6019E	Screw 6 BA x $\frac{1}{2}$.Ch.Hd.	2	
33	W412E	Washer 6 BA Small	2	
34	D4/22/B591	Baffle Plate Assembly	1	
35	D4/5/195J	Screw 6 BA x $\frac{1}{4}$.Mush.Hd.	1	
36	S496E	Screw 4 BA x $\frac{3}{8}$.Ch.Hd.	2	
37	W68E	Washer 4 BA Large	2	3
-	D4/22/A268	Accessory Set and Socket Assy.	1	
38	D4/6/718	Socket, 18-way	1	
39	D4/6/251	Outlet Accessory Set	1	
40	D4/6/119	Plug, 18-way	1	
-	D4/22/A267	Accessory Set and Socket Assy.	1	
41	D4/6/719	Socket, 12-way	1	
42	D4/6/250	Outlet Accessory Set	1	
43	D4/6/118	Plug, 12-way	1	
* 44	S4067J	Screw 4 BA x $\frac{1}{2}$.Inst.Hd.	2	
* 44A	N12E	Nut, 4 BA	2	
* 44B	W400E	Washer 4 BA Small	2	
* 45	D4/6/1428	Polythene Spacer	6	
* 46	T-A 707	Tagboard Assy.	1	
47	{	D4/22/B580	Motor Assy. for 115V 60 c/s supply	1
		D4/22/B584	Motor Assy. for 240V 50 c/s supply	1
48	-	Motor Base	1	

* Items 44-46 are fitted on types TRM 250-218 and TRM 250-219 only.

Item No.	Part No.	Description	No. off	Recommended Spares
49	D4/6/576	Terminal Pin, Crimped	2	
50	D4/6/560	Sleeve 2mm x $\frac{3}{4}$ in. Pink	2	
51	D4/22/A281	Motor Shim	4	
52	S253E	Screw 2 BA x $\frac{3}{8}$ Ch.Hd.	4	1
53	W35E	Washer 2 BA Large	4	1
54	D4/22/A71	Fan Assembly	1	
55	S498E	Screw, Grub, 4 BA x $\frac{1}{4}$ (Slotted)	1	1
-	D4/22/C599	Top Plate Assembly	1	
56	D4/22/D596	Top Plate	1	
57	D4/22/A533	Adjuster (Tape Guide)	2	
58	D4/22/A536	Adjuster Spring	2	
59	D4/6/531	Ball	2	2
60	D4/22/A532	Adjuster Backing Plate	2	
61	D4/5/131J	Screw 6 BA x $\frac{3}{8}$ Inst.Hd.	2	1
62	W36E	Washer 6 BA Plain	2	2
63	N153E	Nut 6 BA Full	2	2
64	D4/5/19	Screw 6 BA x $\frac{1}{4}$ Soc.Hd.Cap	2	4
65	D4/5/140	Washer, Crinkle	2	
-	D4/22/A510	Brake Pad Block Assembly	1	
66	D4/22/A512	Lower Brake Pad	1	1
67	D4/22/A516	Brake Pad Shim 0.002 in. Laminated	A/R	1
68	D4/22/A511	Bottom Plate, Brake	1	
69	D4/5/19	Screw 6 BA x $\frac{1}{4}$ Soc.Hd.Cap	2	
70	D4/5/19	Screw 6 BA x $\frac{1}{4}$ Soc.Hd.Cap	2	
-	D4/22/B560	Brake Cover Assembly	1	
71	D4/22/A529	Brake Cover	1	
72	D4/22/A501	Upper Brake Pad	1	1
73	D4/22/A549	Damping Pad	1	1
74	D4/22/A502	Spacer	1	

Item No.	Part No.	Description	No. off	Recommended Spares
75	D4/22/A505	Brake Spring	1	1
76	D4/22/A508	Brake Pad Pin	2	
77	D4/5/69	Screw 6 BA x $\frac{3}{16}$.Skt.Set	2	1
78	D4/5/204	Screw 6 BA x $\frac{3}{8}$.Skt.Set	1	
79	D4/22/A129	Setting Nut 6 BA	1	1
80	D4/5/298	Hinge Pin $\frac{3}{16}$.dia. x $1\frac{3}{8}$.lg.	1	
81	D4/22/A527	Hinge Block, Left-hand	1	
82	D4/22/A528	Hinge Block, Right-hand	1	
83	D4/22/A537	Brake Cover Spring	1	
84	D4/22/A539	Spring Support	1	
85	D4/5/19	Screw 6 BA x $\frac{1}{4}$.Soc.Hd.Cap	2	
86	W36E	Washer 6 BA Small	2	
87	D4/5/19	Screw 6 BA x $\frac{1}{4}$.Soc.Hd.Cap	4	
88	D4/22/A200	Window	1	2
89	S682J	Screw 6 BA x $\frac{5}{8}$ Inst.Hd.	4	2
-	D4/22/B110	Clutch Assembly	1	1
90	D4/22/B30	Clutch Bracket	1	
91	D4/22/A12	Clutch Roller Bracket Pivot	1	
92	S628E	Screw 6 BA x $\frac{3}{8}$ Ch.Hd.	2	
93	D4/22/B293	Stop Block	1	
94	S6082E	Screw 6 BA x $\frac{9}{16}$.Ch.Hd.	2	1
95	D4/5/241	Screw 4 BA x $\frac{3}{16}$.Grub	1	1
96	S818E	Screw 8 BA x $\frac{1}{4}$.Csk.Hd.	1	1
97	D4/22/A108	Coil	2	2
98	D4/22/A78	Lamination Assembly	1	
99	D4/22/A46	Lower Lamination Clamp	1	
100	D4/22/A63	Bolt 2 BA	2	1
101	N19E	Nut 2 BA	2	1
102	W385E	Washer 2 BA	2	1
103	D4/22/A32	Adjusting Stud 4 BA	1	

Item No.	Part No.	Description	No. off	Recommended Spares
104	N13E	Nut 4 BA	2	1
105	D4/22/A143	Clutch Spring	1	1
106	D4/22/A150	Clutch Roller Bracket	1	
*107	D4/22/A166	Clutch Roller Shaft	1	
*108	D4/22/A173	Pinch Roller	3	
109	{ D4/22A/161 D4/22/A162 D4/22/A128	Roller Spacer	A/R	
		Roller Spacer	A/R	
		Roller Spacer	A/R	
110	D4/22/A27	Locking Plate	1	
111	S1015E	Screw 10 BA x $\frac{3}{32}$.Csk.Hd.	2	2
112	D4/22/A13	Clutch Armature	1	
113	{ D4/22/A116 D4/22/A680	Clutch Armature Shim 0.001 in.	A/R	6
		Clutch Armature Shim 0.005 in.	A/R	1
114	S891E	Screw 8 BA x $\frac{3}{16}$.Ch.Hd.	2	1
115	W227E	Washer 8 BA, Shakeproof	2	2
116	S826	Screw 8 BA x $\frac{1}{4}$.Grub, Brass	2	2
117	N2	Nut 8 BA, Brass	2	2
118	D4/22/A77	Tagboard Assembly	1	
119	D4/22/A57	Insulator	1	
120	S653E	Screw 6 BA x $\frac{3}{8}$.Csk.Hd.	2	1
121	D4/22/A251	Clutch Bracket Shim 0.002 in. Laminated	A/R	
122	S4110E	Screw 4 BA x $\frac{5}{8}$.Ch.Hd.	4	2
123	W275E	Washer 4 BA, Shakeproof	4	3
124	D4/22/A534	Microswitch Bracket	1	
125	S628E	Screw 6 BA x $\frac{3}{8}$.Ch.Hd.	2	
126	N153E	Nut 6 BA	2	

* For replacement parts, a clutch roller/spindle set, consisting of a clutch roller shaft and three selected pinch rollers, is supplied. The part number is A.7462. See Appendix 1 for use of this set.

Item No.	Part No.	Description	No. off	Recommended Spares
127	W412E	Washer 6 BA Small	2	
128	D4/6/509	Microswitch	1	1
129	D4/6/510	Microswitch Actuator	1	
130	S6019E	Screw 6 BA x $1/2$. Ch. Hd.	2	
131	N153E	Nut 6 BA	2	
132	W412E	Washer 6 BA, Small	2	
133	D4/22/A675	Front Cover	1	
134	D4/5/195J	Screw 6 BA x $1/4$. Mush. Hd.	2	
135	D4/22/A677	Monitor Point Cover Assy.	1	
136	D4/6/258	Toggle Switch (ON/OFF)	1	
137	D4/6/363	Microswitch (RUN-OUT)	1	1
138	D4/22/A507	Escutcheon Plate	1	
139	D4/22/A506	Switch Bracket	1	
140	S4109E	Screw 4 BA x $1/2$. Ch. Hd.	2	1
141	W275E	Washer 4 BA, Shakeproof	2	
142	D4/22/A523	Prism Plate Support	2	
143	S432E	Screw 4 BA x $3/8$. Csk. Hd.	4	
144	D4/6/121/2	Flexible Terminal Block 2-way	1	
145	S654E	Screw 6 BA x $5/8$. Ch. Hd.	2	
146	W412E	Washer 6 BA Small	2	
147	D4/22/A666	Bottom Cover Assembly	1	
148	S691E	Screw 6 BA x $5/32$. Ch. Hd.	4	2
149	D4/22/C690	Printed Circuit Board Assy.	2	1
150	D4/22/A685	Printed Circuit Socket Assy. , wired	2	
151	D4/5/231	Screw UNC 8-32 x $1/2$. Ch. Hd.	4	1
152	D4/22/A644	Circuit Board Support Bracket	2	
153	S496E	Screw 4 BA x $3/8$, Ch. Hd.	4	
154	D4/6/136	Plasklip Cable Clip x 4	2	
155	S628E	Screw 6 BA x $3/8$. Ch. Hd.	2	

TRM 250

Item No.	Part No.	Description	No. Recommended off	Spares
156	W412E	Washer 6 BA Small	2	
157	D4/22/A697	Base Support Left-hand Assy. (L. H. front & R. H. rear)	2	
158	D4/22/A659	Monitor Point Plug Sub-Assembly	1	
159	D4/6/967	Resistor 1K., $\frac{1}{8}$ W, 10%	13	
NS	D4/22/A695	Base Support Right-hand Assembly (L. H. rear)	1	
160	D4/5/30	Screw 4 BA x $\frac{3}{8}$. Soc. Hd. Cap	4	
161	W68E	Washer 4 BA Large	4	
-	D4/22/C702	Base Assembly	1	
162	D4/22/D639	Base	1	
165	D4/6/1267	Polythene Foot	4	
166	S488E	Screw 4 BA x $\frac{1}{4}$. Ch. Hd.	4	
167	D4/6/939	Block, 104-way	1	
168	D4/6/947	Pin	11	
169	D4/6/945	Jack Screw Fixed Male	1	
NS	D4/6/946	Jack Screw Fixed Female	1	
170	D4/22/A681	PV Cell Reading Head Assy.	1	1
NS	D4/6/744	Photovoltaic Cell	9	2
171	S621E	Screw 6 BA x $\frac{1}{4}$. Ch. Hd.	4	
* NS	D4/22/C696	PL1 Cableform Assembly	1	
NS	D4/22/C682	PL2 Cableform Assembly	1	
NS	D4/22/B692	PL3 Cableform Assembly	1	
NS	D4/22/A641	Reading Head Mask	1	

* On readers type TRM 250-218 and TRM 250-219 this is replaced by Part No. C.2506.

8.2 Table 2 - Tools and Materials - routine maintenance

1. Cleaning cloth
2. Soft polishing cloth
3. I. C. I. Perspex Polish No. 3.
4. Soft brush $1\frac{1}{2}$ in. wide (10014)
5. Feeler gauges (2020)
6. Screwdrivers
7. Hexagon wrench 0.05 in. A. F. (2034)
8. Hexagon wrench set
9. Castrol S. A. E. 140 oil
10. B. P. CS65 oil
11. Shell Nerita Grease No. 3.
12. Dermic oiler (4306)

8.3 Table 3 - Special Tools

1. AMP Extractor No. 465195-2 (13798)
2. Correx Tension Gauge measuring 50-500 gm. (7065)
3. Salter 32oz. Compression Spring Gauge (13797)
4. Brake and Clutch Test Tape Clamp (1(2/4)A120212)
5. Capstan and Clutch Alignment Gauge (1(2/4)B157021)
6. Capstan Height Gauge (1(2/4)B157022)
7. Slip Gauge (1(2/4)A157024) } if motor is for
8. Slip Gauge (1(2/4)A157027) } 50 c/s operation
9. Slip Gauge (1(2/4)A157025) } if motor is for 60 c/s
operation
10. Mask Setting Gauge (1(2/4)B50145)
11. Tape Width Gauge (1(2/4)A50146)

APPENDIX 1: Use of Clutch Roller/Spindle Set

If a replacement clutch pinch roller (108) or clutch roller shaft (107) is required, a new shaft, complete with three new rollers, must be fitted. These are supplied as a set, Part No. A.7462. The rollers are mounted on the shaft in the correct order and orientation when packed for transit, and this arrangement must be maintained when the parts are fitted in a clutch assembly.

When the set is required for use, the rollers should be removed from the shaft for lubrication, (see para.7.6.1.3) and then replaced in their original positions as the shaft is inserted into the clutch roller bracket (106). New spacers (109) should also be fitted, as required, so that the gap between any two rollers is 0.004 in. to 0.006 in. When the correct spacers have been fitted, re-assemble the remainder of the reader.

An unpunched loop of tape should then be inserted in the reader, and run at the maximum speed of the reader for a period of four hours. At the end of this time dismantle the clutch pinch roller shaft and rollers, and carry out the procedures given in paras.7.6.1.2 to 7.6.1.4. Note that the gap between any two rollers should now be in the range quoted in para.7.6.1.2.

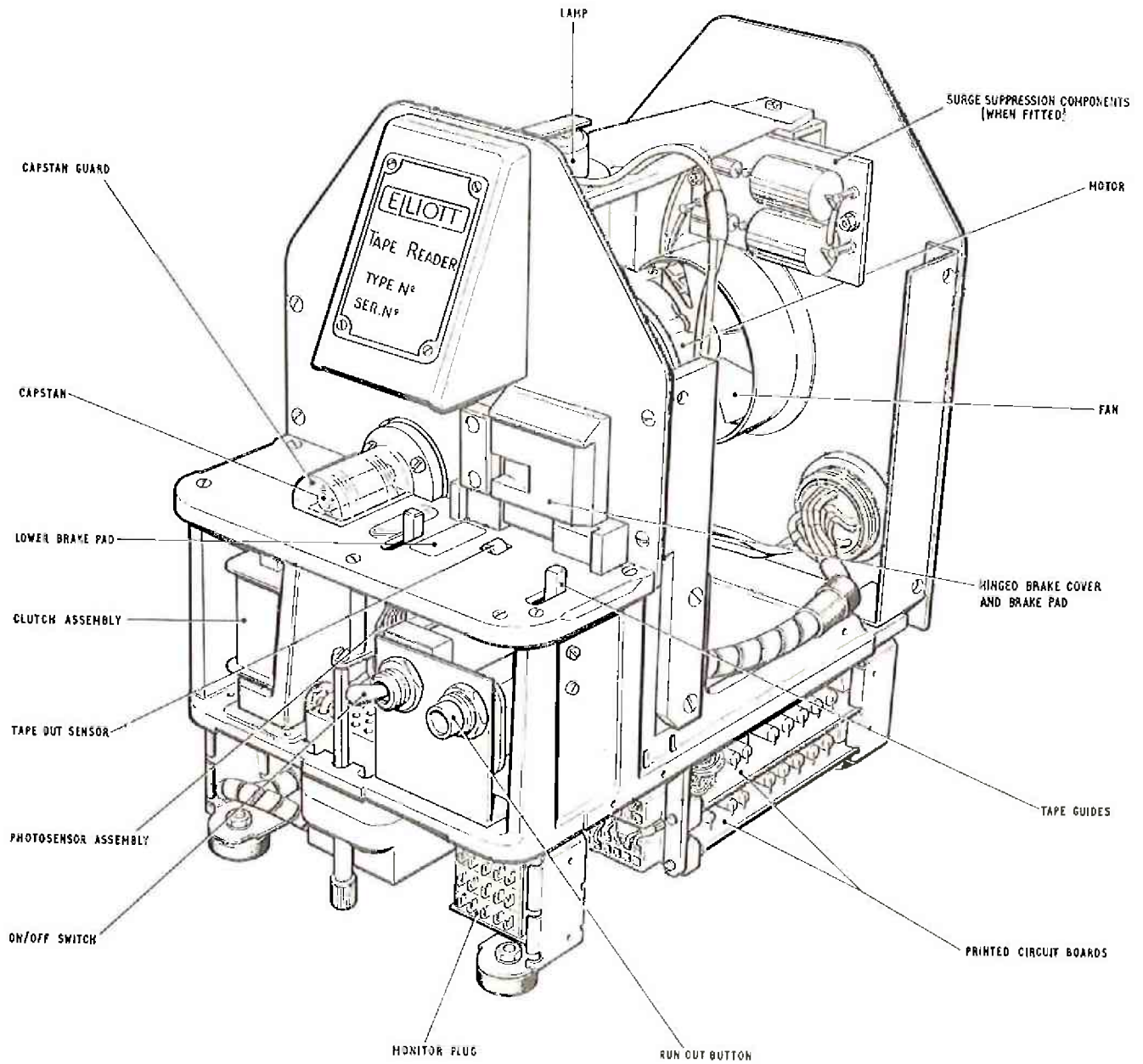

TAPE READER WITH COVERS REMOVED

Figure 2 (ISSUE 2)

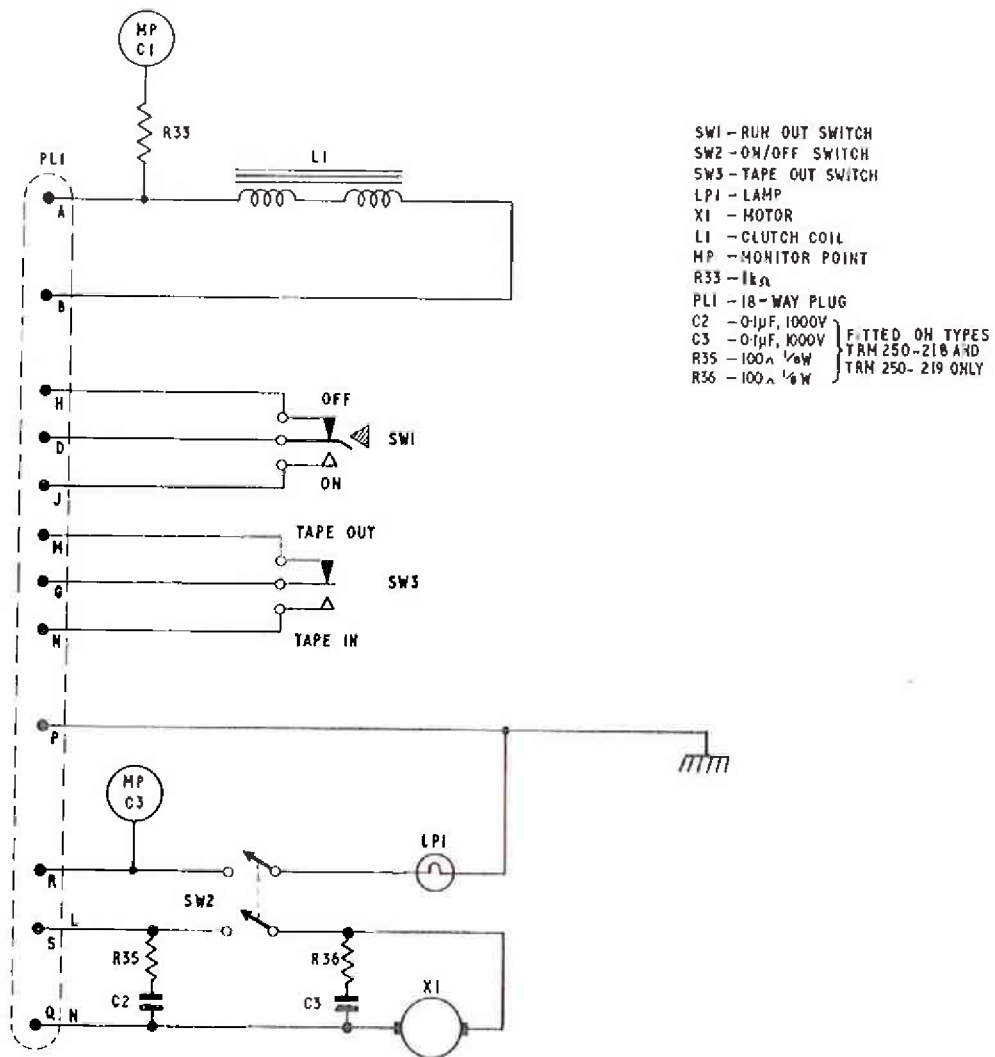

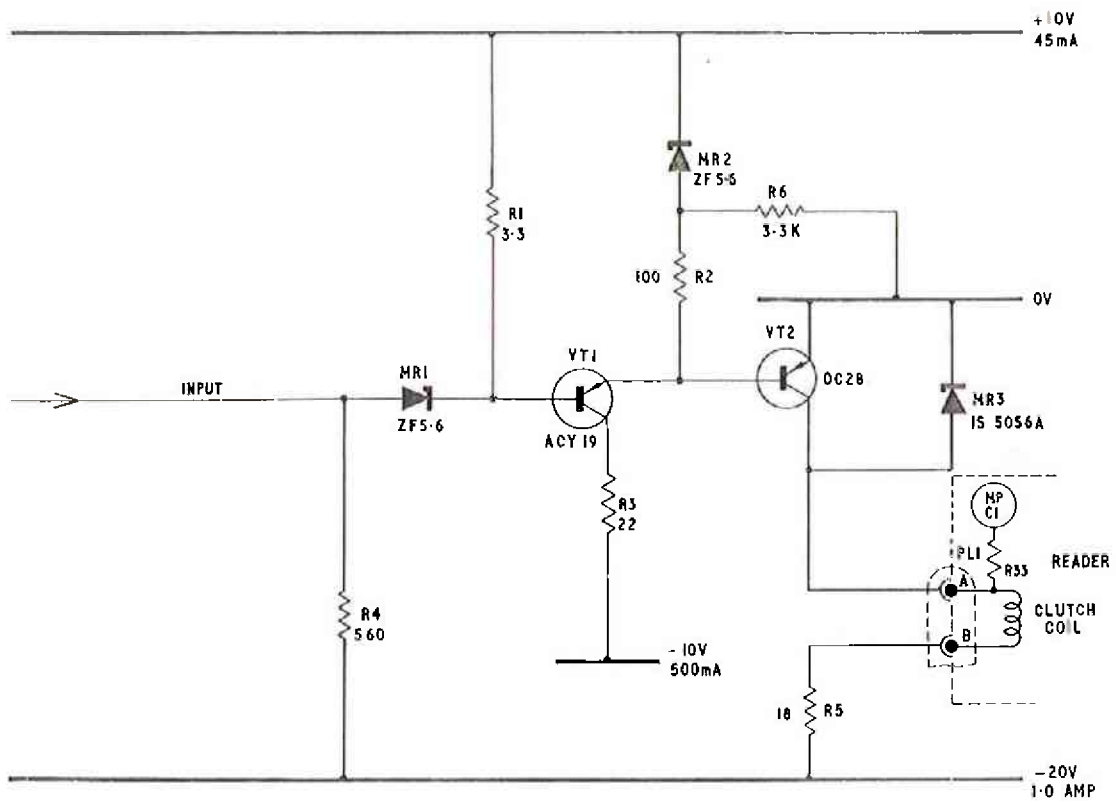

CLUTCH CONTROL-RECOMMENDED CIRCUIT

Figure 4 (ISSUE 2)

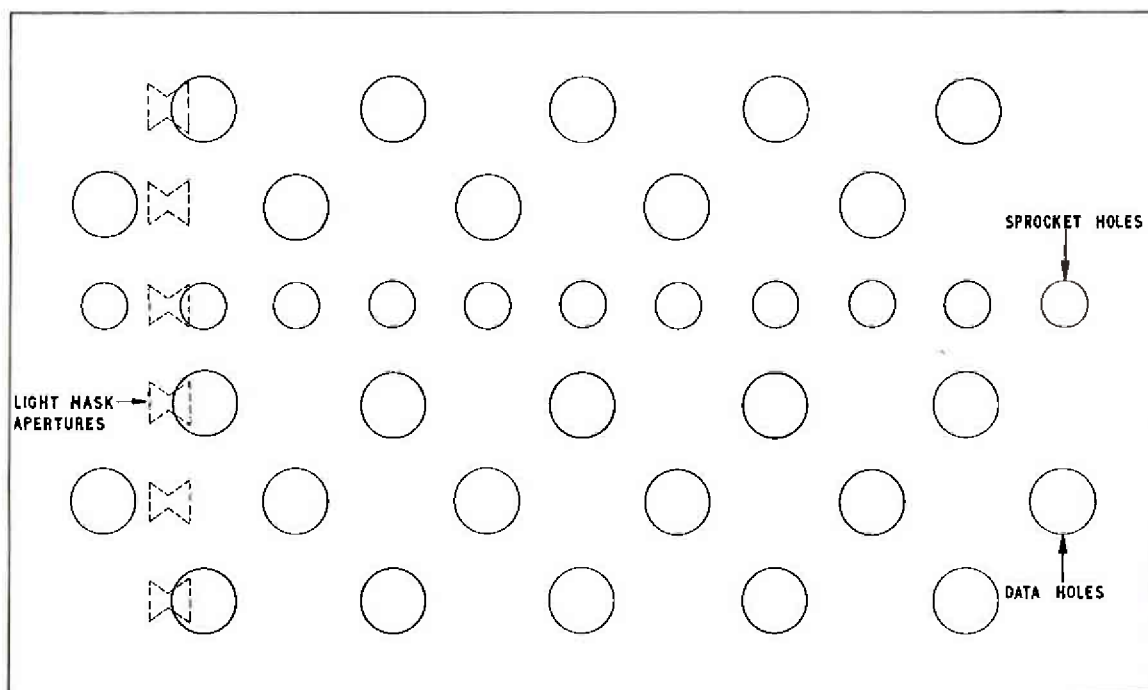

SECTION OF TYPICAL PUNCHED TAPE

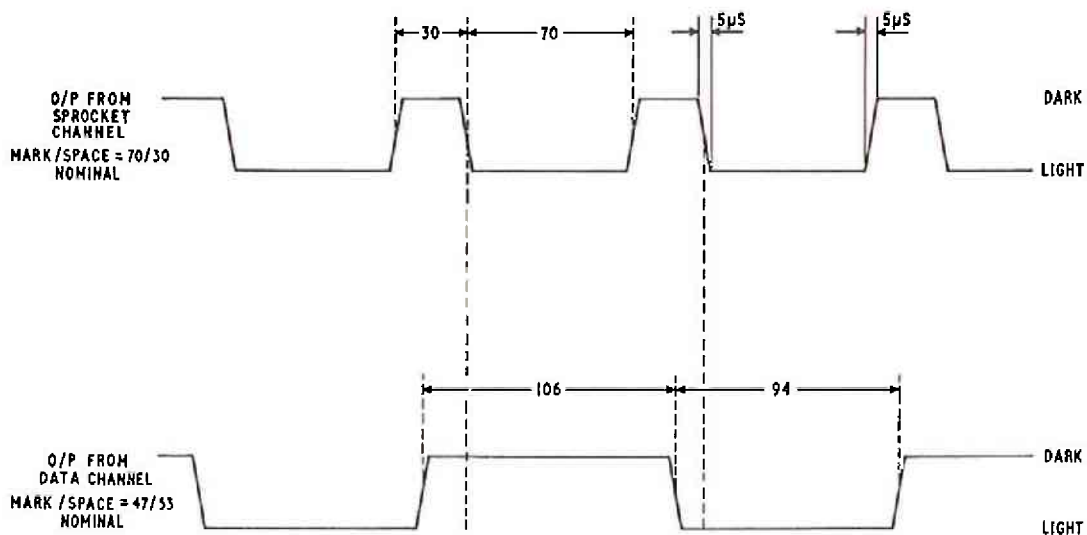

TYPICAL OUTPUT WAVEFORMS FROM TAPE PUNCHED AS SHOWN

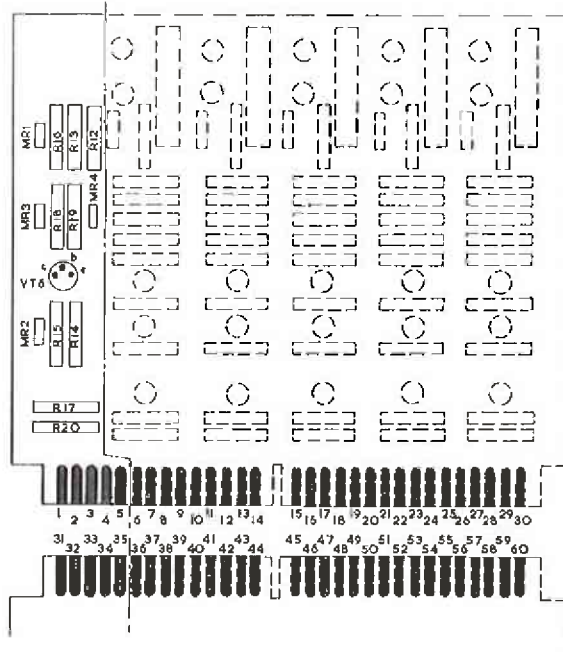

REFERENCE	VALUE OR TYPE No	TOL. %	RATING	PART No.
R12	220	3	1/2 W	D4/6/1966
R13	220	3	1/2 W	D4/6/1966
R14	220	3	1/2 W	D4/6/1966
R15	220	3	1/2 W	D4/6/1966
R16	27K	3	1/2 W	D4/6/1963
R17	1K	3	1/2 W	D4/6/1964
R18	820	3	1/2 W	D4/6/1957
R19	1K	3	1/2 W	D4/6/1964
R20	56K	3	1/2 W	D4/6/1965
MR1	ZF3-3			D4/6/968
MR2	ZF3-3			D4/6/968
MR3	0A200			D4/6/418
MR4	0A200			D4/6/418
VT6	25701			D4/6/578
MR3 & 4	Z6120		ALTERNATIVE TYPE	D4/6/1401

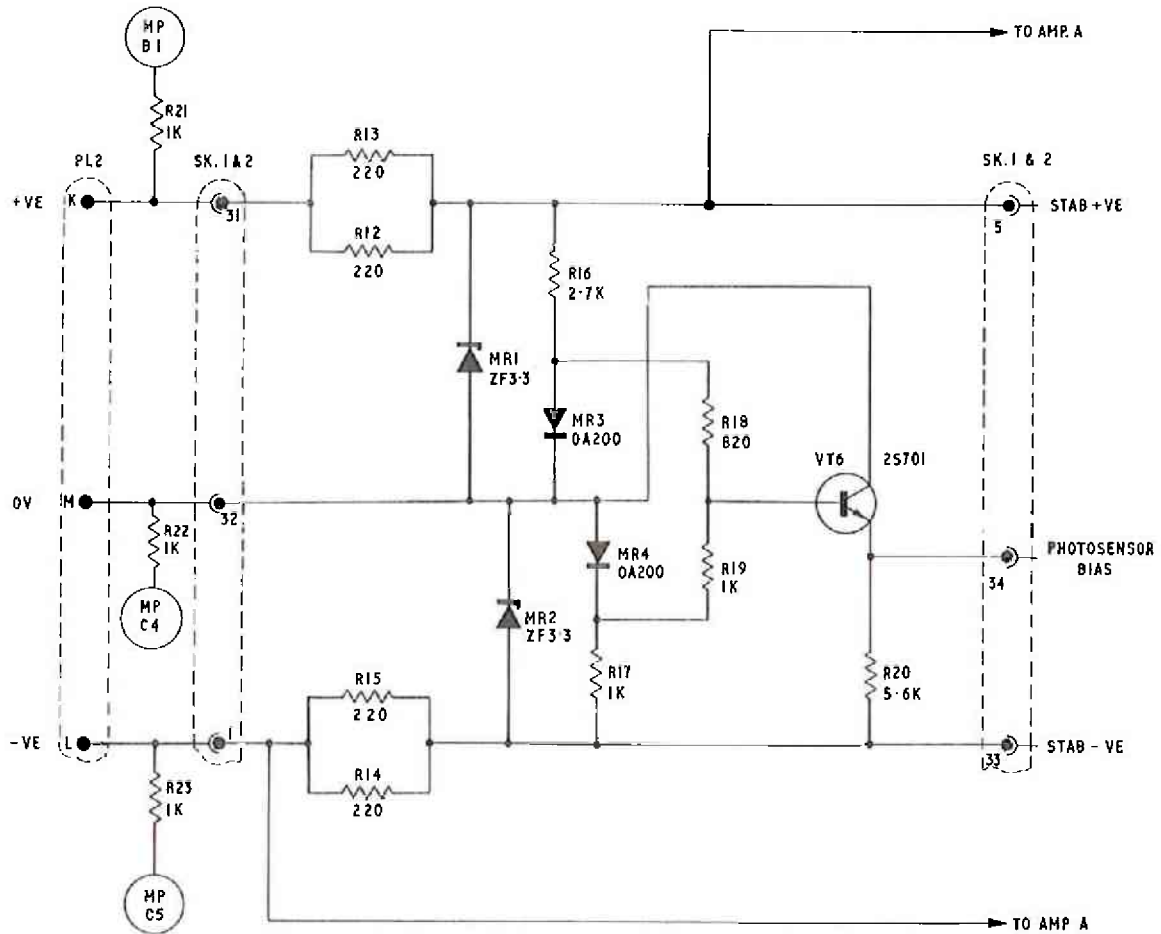

- SK 1 - } PRINTED CIRCUIT
- SK 2 - } BOARD SOCKETS
- PL 2 - 12 WAY PLUG
- MP - MONITOR POINT
- R21 TO 23 - MONITOR POINT RESISTORS, 1K, 1/8W, 10%

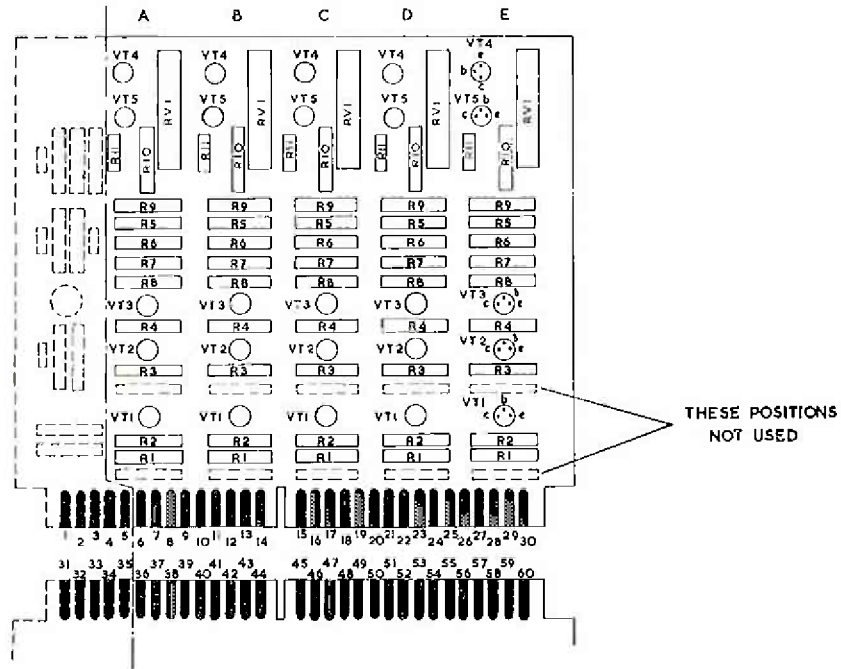

REFERENCE	VALUE OR TYPE No.	TOL%o	RATING	PART No.
R1	15K	3	1/2W	13179
R2	68	3	1/2W	D4 / 6 / 1955
R3	4.7K	3	1/2W	D4 / 6 / 1956
R4	820	3	1/2W	D4 / 6 / 1957
R5	1.5K	3	1/2W	D4 / 6 / 1958
R6	4.7K	3	1/2W	D4 / 6 / 1958
R7	1.8K	3	1/2W	D4 / 6 / 1958
R8	390	3	1/2W	D4 / 6 / 1959
R9	33K	3	1/2W	D4 / 6 / 1960
R10	470	3	1/2W	D4 / 6 / 1961
R11	560	3	1/2W	D4 / 6 / 1962
RVI	100K			13364
VT1	25323			D4 / 6 / 875
VT2	25323			D4 / 6 / 875
VT3	25323			D4 / 6 / 875
VT4	25323			D4 / 6 / 875
VT5	25323			D4 / 6 / 875
VT1 - VT5	V205 253230	ALTERNATIVE TYPES		D4 / 6 / 1573 D4 / 6 / 1942

Figure 8 (ISSUE 2)

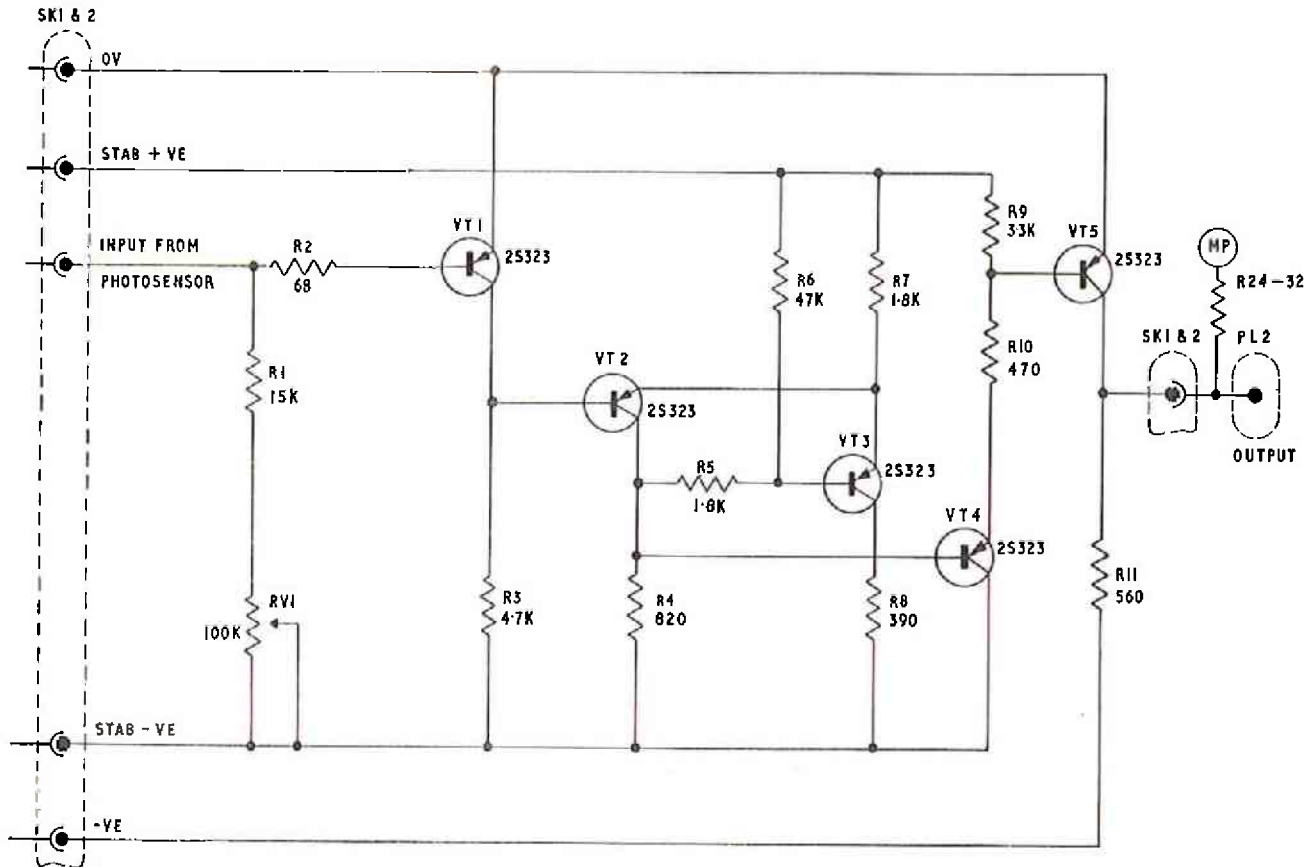

- SK1 - PRINTED CIRCUIT
- SK2 - BOARD SOCKETS
- PL2 - 12-WAY PLUG
- MP - MONITOR POINT
- R24 TO 32 - MONITOR POINT RESISTORS, 1K Ω , 1/8W, 10%.

NOTE:
ON EARLIER MODELS R1 WAS 53K, AND RV1 WAS 50K.

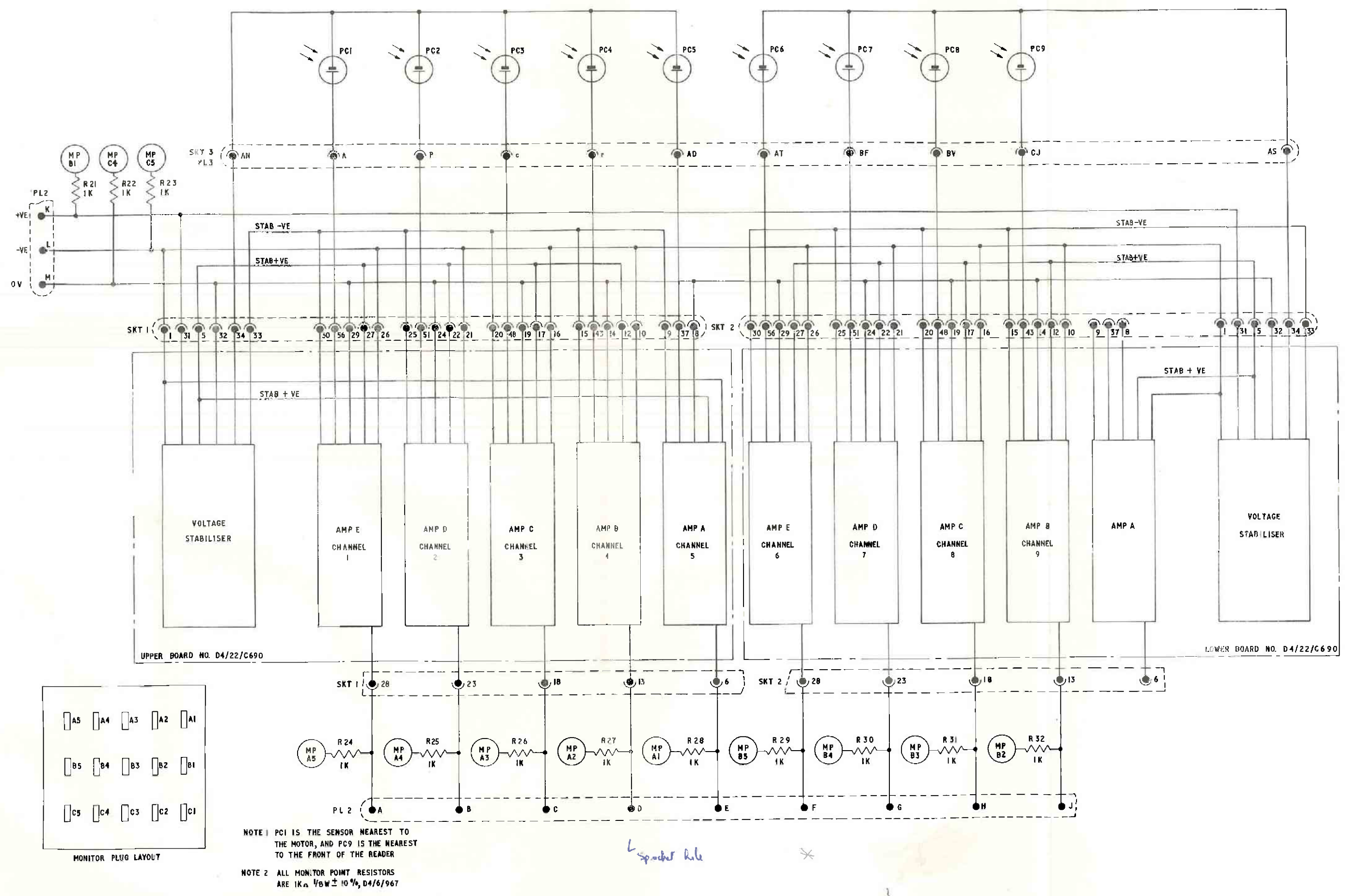

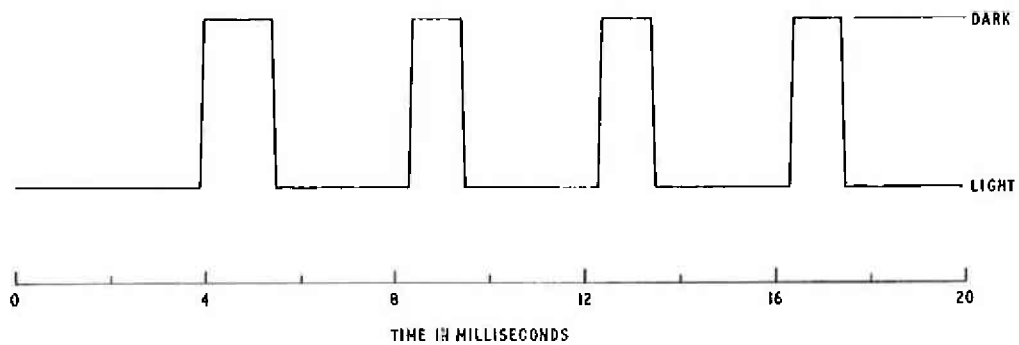

NOTES:-

1. THE DIAGRAM SHOWS THE WAVEFORM FROM THE SPROCKET AMPLIFIER, WHEN THE CLUTCH IS ENERGISED AT THE ZERO POINT ON THE TIME SCALE.
2. THE POSITION OF THE TAPE AT ZERO TIME IS AS DESCRIBED IN PARA. 6. 4.
3. THE CLUTCH ENERGISING CURRENT IS SUPPLIED FROM THE CIRCUIT SHOWN IN FIG.4, AND IS MAINTAINED THROUGHOUT THE PERIOD SHOWN.

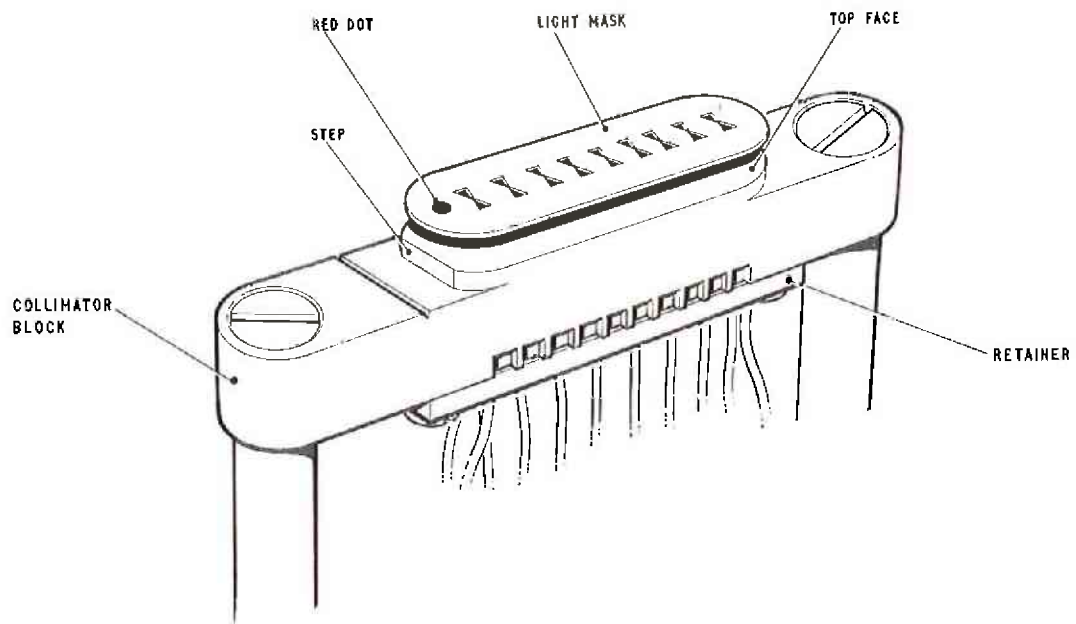

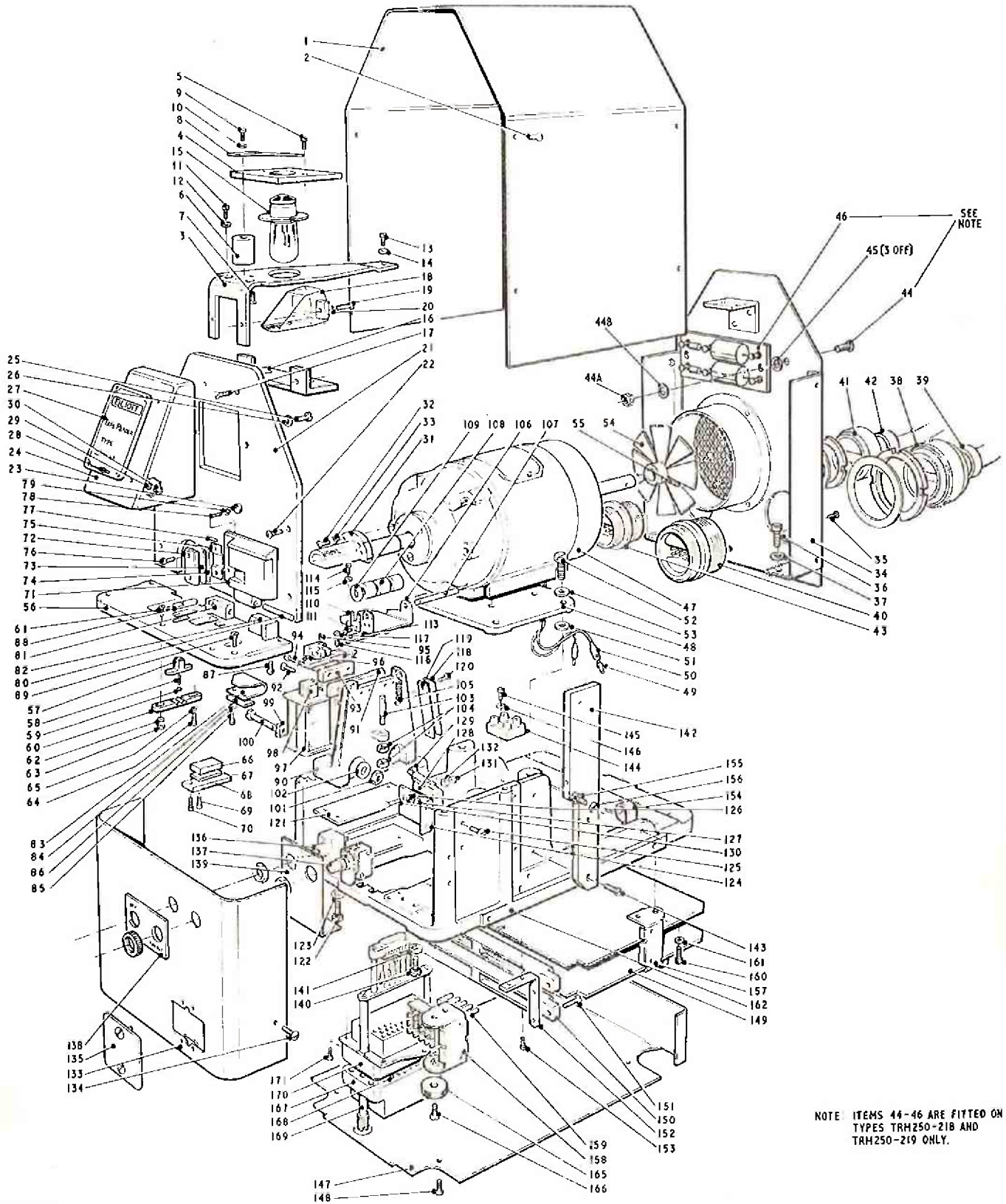

NOTE: ITEMS 44-46 ARE FITTED ON TYPES TRM250-21B AND TRM250-219 ONLY.